

Service Manual

Feeder

DADF-M1

Canon

Mar 22 2004

Application

This manual has been issued by Canon Inc. for qualified persons to learn technical theory, installation, maintenance, and repair of products. This manual covers all localities where the products are sold. For this reason, there may be information in this manual that does not apply to your locality.

Corrections

This manual may contain technical inaccuracies or typographical errors due to improvements or changes in products. When changes occur in applicable products or in the contents of this manual, Canon will release technical information as the need arises. In the event of major changes in the contents of this manual over a long or short period, Canon will issue a new edition of this manual.

The following paragraph does not apply to any countries where such provisions are inconsistent with local law.

Trademarks

The product names and company names used in this manual are the registered trademarks of the individual companies.

Copyright

This manual is copyrighted with all rights reserved. Under the copyright laws, this manual may not be copied, reproduced or translated into another language, in whole or in part, without the written consent of Canon Inc.

COPYRIGHT © 2001 CANON INC.









Printed in Japan

Caution

Use of this manual should be strictly supervised to avoid disclosure of confidential information.



Symbols Used

This documentation uses the following symbols to indicate special information:

Symbol	Description
	Indicates an item of a non-specific nature, possibly classified as Note, Caution, or Warning.
	Indicates an item requiring care to avoid electric shocks.
	Indicates an item requiring care to avoid combustion (fire).
	Indicates an item prohibiting disassembly to avoid electric shocks or problems.
	Indicates an item requiring disconnection of the power plug from the electric outlet.
 Memo	Indicates an item intended to provide notes assisting the understanding of the topic in question.
 REF.	Indicates an item of reference assisting the understanding of the topic in question.
	Provides a description of a service mode.
	Provides a description of the nature of an error indication.

The following rules apply throughout this Service Manual:

1. Each chapter contains sections explaining the purpose of specific functions and the relationship between electrical and mechanical systems with reference to the timing of operation.

In the diagrams,  represents the path of mechanical drive; where a signal name accompanies the symbol, the arrow  indicates the direction of the electric signal.

The expression "turn on the power" means flipping on the power switch, closing the front door, and closing the delivery unit door, which results in supplying the machine with power.

2. In the digital circuits, '1' is used to indicate that the voltage level of a given signal is "High", while '0' is used to indicate "Low". (The voltage value, however, differs from circuit to circuit.) In addition, the asterisk (*) as in "DRMD*" indicates that the DRMD signal goes on when '0'.

In practically all cases, the internal mechanisms of a microprocessor cannot be checked in the field. Therefore, the operations of the microprocessors used in the machines are not discussed: they are explained in terms of from sensors to the input of the DC controller PCB and from the output of the DC controller PCB to the loads.

The descriptions in this Service Manual are subject to change without notice for product improvement or other purposes, and major changes will be communicated in the form of Service Information bulletins.

All service persons are expected to have a good understanding of the contents of this Service Manual and all relevant Service Information bulletins and be able to identify and isolate faults in the machine."

Contents

Chapter 1 Specifications

1.1 Product Specifications	1- 1
1.1.1 Specifications	1- 1
1.2 Names of Parts.....	1- 4
1.2.1 External View	1- 4
1.2.2 Cross Section	1- 4
1.3 Using the Machine.....	1- 6
1.3.1 Original Placement Indicator.....	1- 6
1.3.2 Warning and Action to Take	1- 6

Chapter 2 Functions

2.1 Basic Construction	2- 1
2.1.1 Overview of the Electrical Circuitry	2- 1
2.1.2 Inputs to the ADF Controller PCB	2- 1
2.1.3 Outputs from the ADF Driver PCB	2- 2
2.2 Basic Operation	2- 4
2.2.1 Routes of Drive	2- 4
2.2.2 Overview of Operation Modes	2- 5
2.2.3 Normal Rotation Pickup/Reversal Operation (single-sided original -> signal-side print).....	2- 7
2.2.4 Normal Rotation Pickup/Delivery Operation (double-sided original -> double-sided print)	2- 7
2.2.5 Normal Rotation Pickup/Reversal Delivery (double-sided original -> double-sided print).....	2- 13
2.2.6 Idle Feed/Reversal Pickup/Delivery (single-sided original of mixed configurations -> single-sided print) .	2- 15
2.3 Document Detection.....	2- 19
2.3.1 Overview	2- 19
2.3.2 Checking the Presence/Absence of an Original	2- 20
2.3.3 Identifying the Size of the Original	2- 21
2.4 Document Pickup/Separation	2- 29
2.4.1 Basic Sequence of Operation	2- 29
2.4.2 Pickup Unit and the Stopper.....	2- 31
2.4.3 Timing of Pickup.....	2- 31
2.4.4 Controlling the Pickup Motor (M1)	2- 32
2.4.5 Controlling the Lock Motor (M4)	2- 32
2.5 Document Reversing	2- 34
2.5.1 Basic Sequence of Operation	2- 34
2.5.2 Sequence of Operation	2- 35
2.5.3 Controlling the Delivery Reversal Motor (M3)	2- 36
2.6 Document Feeding/Delivery	2- 37
2.6.1 Basic Sequence of Operation	2- 37
2.6.2 Sequence of Operation	2- 38
2.6.3 Controlling the Feed Motor.....	2- 38
2.7 Detecting Jams	2- 39

2.7.1 JAM	2- 39
2.8 Power Supply	2- 40
2.8.1 Power Supply	2- 40
2.9 Stamp Operation	2- 41
2.9.1 Overview	2- 41

Chapter 3 Parts Replacement Procedure

3.1 Removing from the Host Machine	3- 1
3.1.1 Feeder	3- 1
3.2 External Covers	3- 3
3.2.1 Front Cover	3- 3
3.2.2 Rear Cover	3- 3
3.2.3 Lower Left Cover	3- 3
3.2.4 Feeder Cover	3- 3
3.3 Drive System	3- 5
3.3.1 Pickup Motor	3- 5
3.3.2 Feed Motor	3- 5
3.3.3 Delivery Reversal Motor	3- 6
3.3.4 Pressurization Motor	3- 7
3.3.5 Drive Unit	3- 8
3.4 Document Feeding System	3- 10
3.4.1 Pickup Roller Unit	3- 10
3.4.2 Pickup Roller / Feed Roller	3- 10
3.4.3 Separation Plate/Separation Pad	3- 11
3.4.4 No.1 Registration Roller Roll	3- 12
3.4.5 No.1 Registration Roller	3- 14
3.4.6 No.2 Registration Roller Roll	3- 16
3.4.7 No.2 Registration Roller	3- 17
3.4.8 Delivery Reversing Roller (upper)	3- 18
3.4.9 Read Roller 1	3- 20
3.4.10 Platen Roller	3- 25
3.4.11 Platen Roller Roll Upstream	3- 25
3.4.12 Platen Roller Roll Downstream	3- 29
3.4.13 Delivery Reversing Roller (lower)	3- 30
3.4.14 Reversing Roller	3- 30
3.4.15 Reversion Roller Roll	3- 33
3.4.16 Open/Close Guide Sheet	3- 33
3.4.17 Duct-Collection Sheet	3- 33
3.5 Electrical System	3- 35
3.5.1 Fan	3- 35
3.5.2 Document Width Volume	3- 35
3.5.3 Pressurization Solenoid	3- 37
3.5.4 ADF Driver PCB	3- 37
3.5.5 Separation Sensor	3- 38
3.5.6 Read Sensor	3- 38
3.5.7 Delivery Reversal Sensor	3- 39

Chapter 4 Maintenance

4.1 User Maintenance	4- 1
4.1.1 Cleaning.....	4- 1
4.1.2 Replacement	4- 2
4.2 Maintenance and Inspection.....	4- 3
4.2.1 Periodically Replaced Parts	4- 3
4.2.2 Durables	4- 3
4.2.3 Periodical Servicing	4- 4
4.2.4 Cleaning	4- 7
4.3 Adjustment	4- 20
4.3.1 Basic Adjustment	4- 20
4.3.2 Adjustment at Time of Parts Replacement	4- 27
4.4 Outline of Electrical Components	4- 30
4.4.1 Sensors.....	4- 30
4.4.2 Motors, Clutches, Solenoids, PCBs, and Others	4- 31
4.5 Variable Resistors (VR), Light-Emitting Diodes (LED), and Check Pins by PCB	4- 33
4.5.1 Overview	4- 33
4.5.2 ADF Driver PCB	4- 33
4.5.3 Original Placement led PCB.....	4- 33

Chapter 5 Error Code

5.1 Overview	5- 1
5.1.1 Overview	5- 1
5.1.2 Error Code	5- 2
5.2 User Error Code.....	5- 3
5.2.1 Alarm Code	5- 3

Chapter 1 Specifications

Contents

1.1 Product Specifications	1-1
1.1.1 Specifications	1-1
1.2 Names of Parts.....	1-4
1.2.1 External View.....	1-4
1.2.2 Cross Section	1-4
1.3 Using the Machine.....	1-6
1.3.1 Original Placement Indicator.....	1-6
1.3.2 Warning and Action to Take	1-6

1.1 Product Specifications

1.1.1 Specifications

0002-7206

T-1-1

Item	Description	Remarks
Pickup method	auto pickup/delivery	
Original type	sheet, book	
Original weight	Black-and-White single-sided sheet: AB: 42 to 128 g/m2 inch: 50 to 128 g/m2 double-sided sheet: 50 to 128 g/m2	If longer than 432 mm, must be fed individually: 60 to 90 g/m2
	Color 64 to 128 g/m2	
	Black-and-White w/ Color 50 to 128 g/m2	
Original size	Size B6, A5 (STMT) to A3 (11x17)	Note: If B6, cross- feed direction only.
	Feed Direction 128.0 to 432.0 mm (extra-length mode: 630 mm)	
	Cross-Feed Direction 139.7 to 297.0 mm (304.8 mm max.)	
Original placement	Original Tray face-up	
Original orientation	Original Tray center reference	
Original reading method	stream reading	
Original separation	top separation	
Original feed mode	single-sided/double-sided	

Original tray capacity	100 sheets (paper of 80 g/m ² or less)	
	if in excess of 80 g/m ² , as appropriately converted	
	if folded, stack must be 13 mm or less in height	
	if in excess of 432 mm, single placement only if in excess of 432 mm, single placement only	
Original mix	yes (mix of same configurations)	Note: Be sure to place originals against the rear end.
	yes (mix of different configurations)	
	Combination of Configurations AB: 13/B4, B4/A4R, A4/B5, B5/A5	
Original size identification	width: by pickup tray side guide platewidth: by pickup tray side guide plate	
	length: by sensor and LGL sensor on tray	
Residual original detection	yes (in conjunction with host machine)	
DONE stamp	yes	Note: optionally set (in service mode).
Original processing speed	single-sided: 50 ipm	
	double-sided: 25 ipm	
	high-speed double-sided (A4/LTR): 35 ipm (default)	
Communication with reader unit	serial	
Power supply	24 VDC, 13 VDC (from host machine)	
Weight	14.7 kg (approx.)	
Dimensions	575.5 (W) x 552.3 (D) x 151.2 (H) mm	

Operating environment	same as host machine	
temperature		
humidity		

*1: To enable extra-length mode, use the following service mode item: COPIER>OPTION>USER>MF-LG-SET; to enable, select '1'; to disable, select '0', which is the default.

1.2 Names of Parts

1.2.1 External View

0002-7211

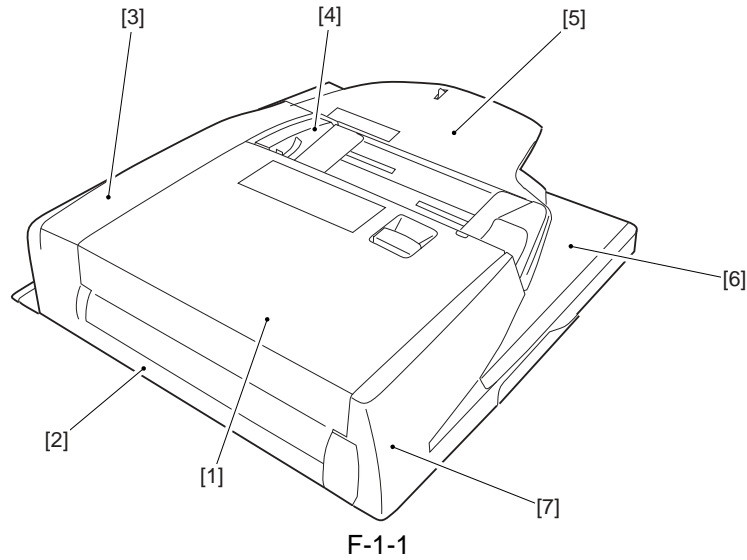

- 1 Feeder cover
- 2 Lower left cover
- 3 Rear cover
- 4 Slide guide
- 5 Original pickup tray
- 6 Original delivery assembly
- 7 Front cover

1.2.2 Cross Section

0002-7213

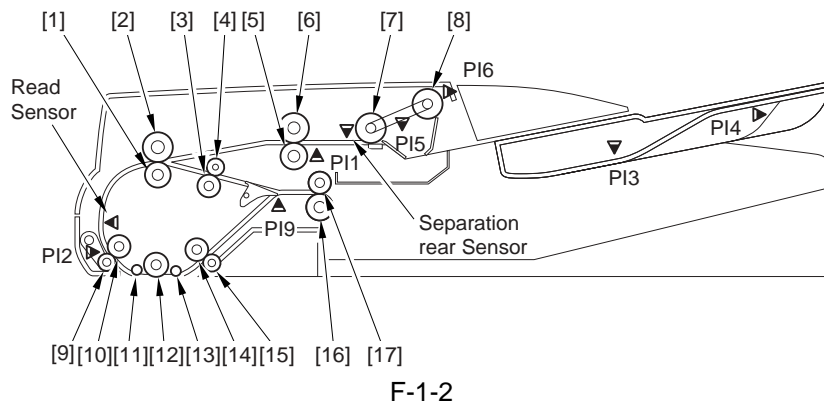

- 1 No. 2 registration roller, lower

- 2 No. 2 registration roller, upper
- 3 Reversing roller, lower
- 4 Reversing roller, upper
- 5 No. 1 registration roller, lower
- 6 No. 1 registration roller, upper
- 7 Separation roller
- 8 Pickup roller
- 9 Read roll 1
- 10 Read roller 1
- 11 Platen roll 1
- 12 Platen roller
- 13 Platen roll 2
- 14 Read roller 2
- 15 Read roll 2
- 16 Delivery reversing roller, lower
- 17 Delivery reversing roller, upper

1.3 Using the Machine

1.3.1 Original Placement Indicator

0002-7214

The original placement indicator goes on when an original is placed in the original tray, and it flashes to indicate the presence of a jam.

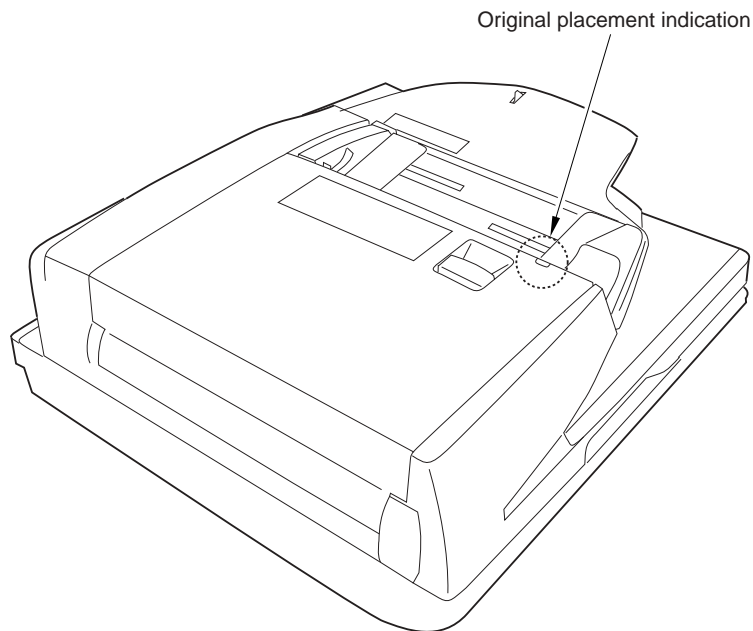

F-1-3

1.3.2 Warning and Action to Take

0002-7215

If the original placement indicator starts to flash while an original is being moved, suspect a jam, and go through the following:

- 1) Check all originals in the tray.
- 2) Open the feeder cover, and remove any jammed original.
- 3) Put the originals in order starting from 1st to last page, and place the stack back in the ADF.

Chapter 2 Functions

Contents

2.1 Basic Construction	2-1
2.1.1 Overview of the Electrical Circuitry	2-1
2.1.2 Inputs to the ADF Controller PCB	2-1
2.1.3 Outputs from the ADF Driver PCB.....	2-2
2.2 Basic Operation	2-4
2.2.1 Routes of Drive	2-4
2.2.2 Overview of Operation Modes	2-5
2.2.3 Normal Rotation Pickup/Reversal Operation (single-sided original -> signal-side print).....	2-7
2.2.4 Normal Rotation Pickup/Delivery Operation (double-sided original -> double-sided print)	2-7
2.2.5 Normal Rotation Pickup/Reversal Delivery (double-sided original -> double-sided print).....	2-13
2.2.6 Idle Feed/Reversal Pickup/Delivery (single-sided original of mixed configurations -> single-sided print) 2-15	
2.3 Document Detection.....	2-19
2.3.1 Overview	2-19
2.3.2 Checking the Presence/Absence of an Original	2-20
2.3.3 Identifying the Size of the Original	2-21
2.4 Document Pickup/Separation	2-29
2.4.1 Basic Sequence of Operation	2-29
2.4.2 Pickup Unit and the Stopper.....	2-31
2.4.3 Timing of Pickup.....	2-31
2.4.4 Controlling the Pickup Motor (M1)	2-32
2.4.5 Controlling the Lock Motor (M4)	2-32
2.5 Document Reversing	2-34
2.5.1 Basic Sequence of Operation	2-34
2.5.2 Sequence of Operation	2-35
2.5.3 Controlling the Delivery Reversal Motor (M3)	2-36
2.6 Document Feeding/Delivery	2-37
2.6.1 Basic Sequence of Operation	2-37
2.6.2 Sequence of Operation	2-38
2.6.3 Controlling the Feed Motor	2-38
2.7 Detecting Jams	2-39
2.7.1 JAM	2-39
2.8 Power Supply	2-40
2.8.1 Power Supply	2-40
2.9 Stamp Operation.....	2-41
2.9.1 Overview	2-41

2.1 Basic Construction

2.1.1 Overview of the Electrical Circuitry

0002-7181

The machine is not equipped with a controller PCB, and its electrical mechanisms are controlled by the reader controller PCB, which serves as a CPU (IC1). The CPU interprets signals from sensors and the host machine to generate signals used to drive DC loads (e.g., motor, solenoid) with the help of the CPU (IC9) of the ADF driver PCB.

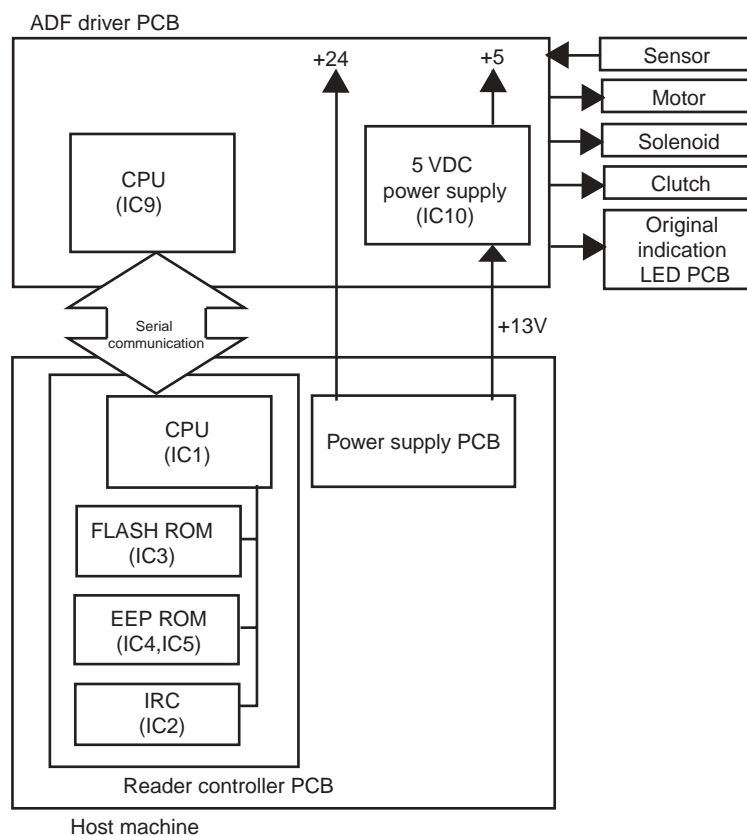

F-2-1

2.1.2 Inputs to the ADF Controller PCB

0002-7187

Inputs to the ADF Driver PCB (1/1)

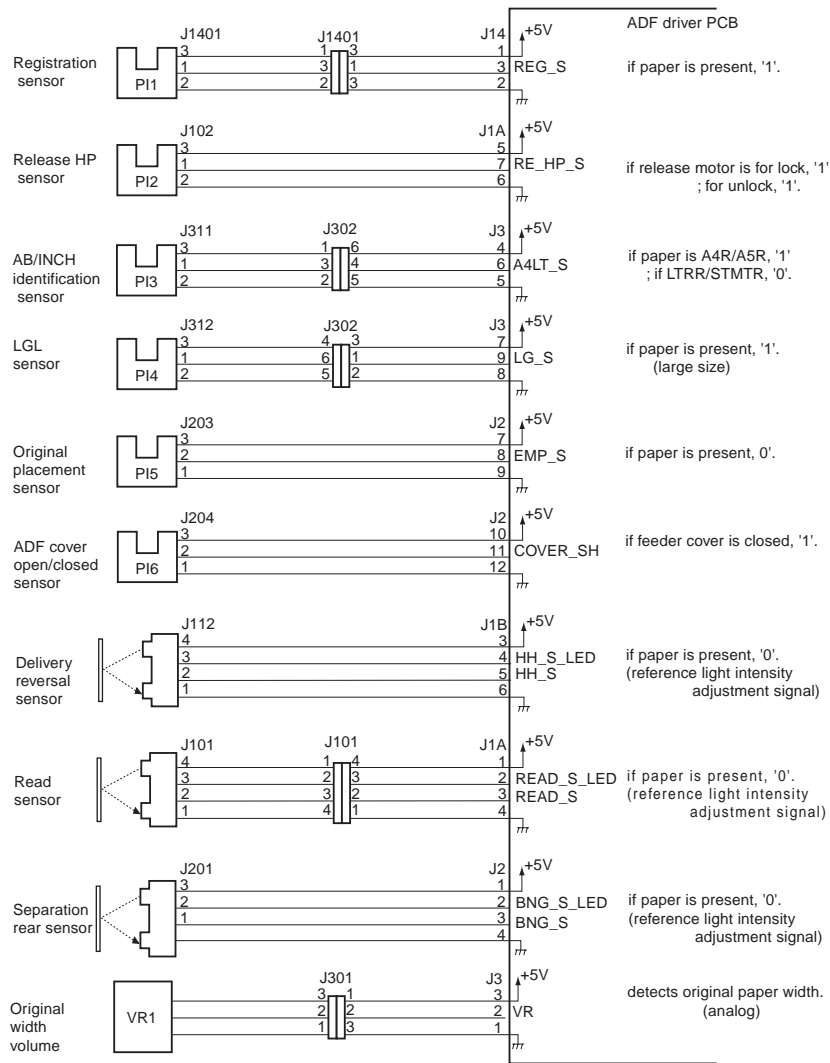

F-2-2

2.1.3 Outputs from the ADF Driver PCB

0002-7192

Outputs from the ADF Driver PCB (1/1)

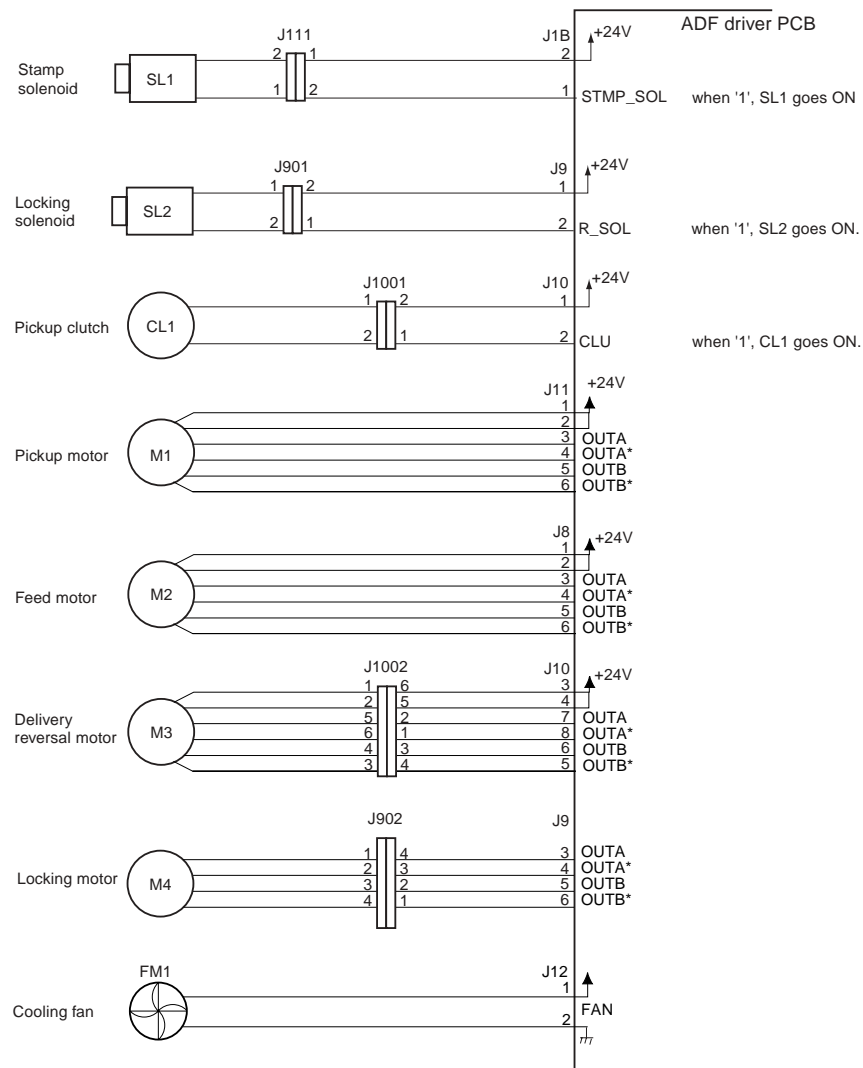

F-2-3

2.2 Basic Operation

2.2.1 Routes of Drive

0002-7230

The machine is a document feeder exclusively designed for stream reading mode, and it uses 4 motors and 1 clutch to control the movement of originals.

T-2-1

Name	Description
Pickup motor (M1)	picks up/feed originals
Feed motor (M2)	feeds originals.
Delivery reversal motor (M3)	delivers or reverses originals.
Drive motor (M4)	moves the read roll 1.
Pickup clutch (CL1)	permits or cuts the drive from the pickup motor (M1) to the pickup roller and the feed roller (drive system).

The following is a diagram of the machine' s routes of drive:

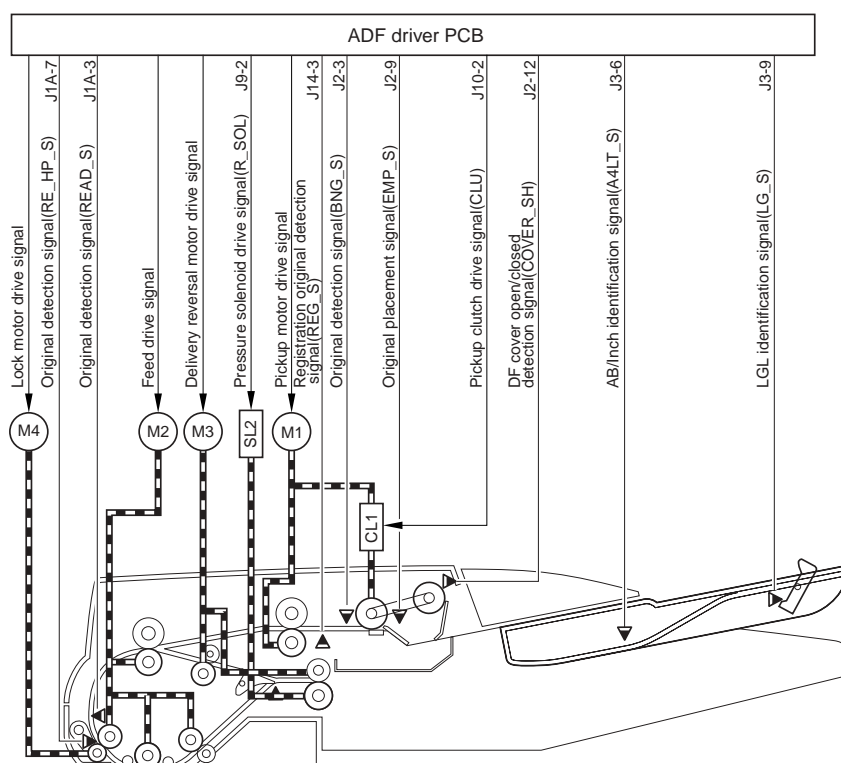

F-2-4

2.2.2 Overview of Operation Modes

0002-7275

MEMO

The machine executes the following 4 types of operation mode, executing individual modes according to the instructions from the host machine for printing. The following table shows these operation modes, outlines of the modes, and corresponding printing modes:

T-2-2

Operation mode	Outline of operation	Corresponding printing mode
1. Normal rotation pickup/delivery	picks up an original, and delivers it after it has been read.	single-sided original -> single-sided print
		single-sided original -> double-sided print
		extra-length original>single-sided print

2. Normal rotation pickup/reversal delivery	picks up an original, and reverses and delivers it after it has been read.	double-sided original -> double-sided print
		double-sided original -> single-sided print
3. Idle feed/reversal pickup/reversal delivery	executes idle feed to find out the size of the original; then, executes idle feed so that the reading may start with the face of the original; then, picks up, reverses, and delivers it after it has been read.	double-sided original of different configurations -> double-sided print
		double-sided original of different configurations -> single-sided print
		double-sided original of same configuration -> double-sided print (inch-configuration only)
		double-sided original of same configuration -> single-sided prints (inch-configuration only)
4. Idle feed/reversal pickup/delivery	executes idle feed to identify the size of the originals, reverses it, and delivers it after it has been read.	single-sided original of different configurations -> single-sided print
		single-sided-original of different configurations -> double-sided print
		single-sided original of same configuration -> double-sided print (inch-configuration only)
		single-sided original of same configuration -> single-sided print (inch-configuration only)

MEMO

The machine executes idle rotation for a mix of sheets of the same configuration only if it identifies the paper in the tray at the beginning of the copy job as being LGL.

A sheet of paper is identified as follows in terms of size:

small-size: B6, A5, A4, B5, LTR, STMT

large-size: A4R, B5R, A3, B4, LTRR, LGL, 279.4X431.8 mm (11x17)

2.2.3 Normal Rotation Pickup/Reversal Operation (single-sided original -> signal-side print)

0002-7281

The following shows the flow of originals:

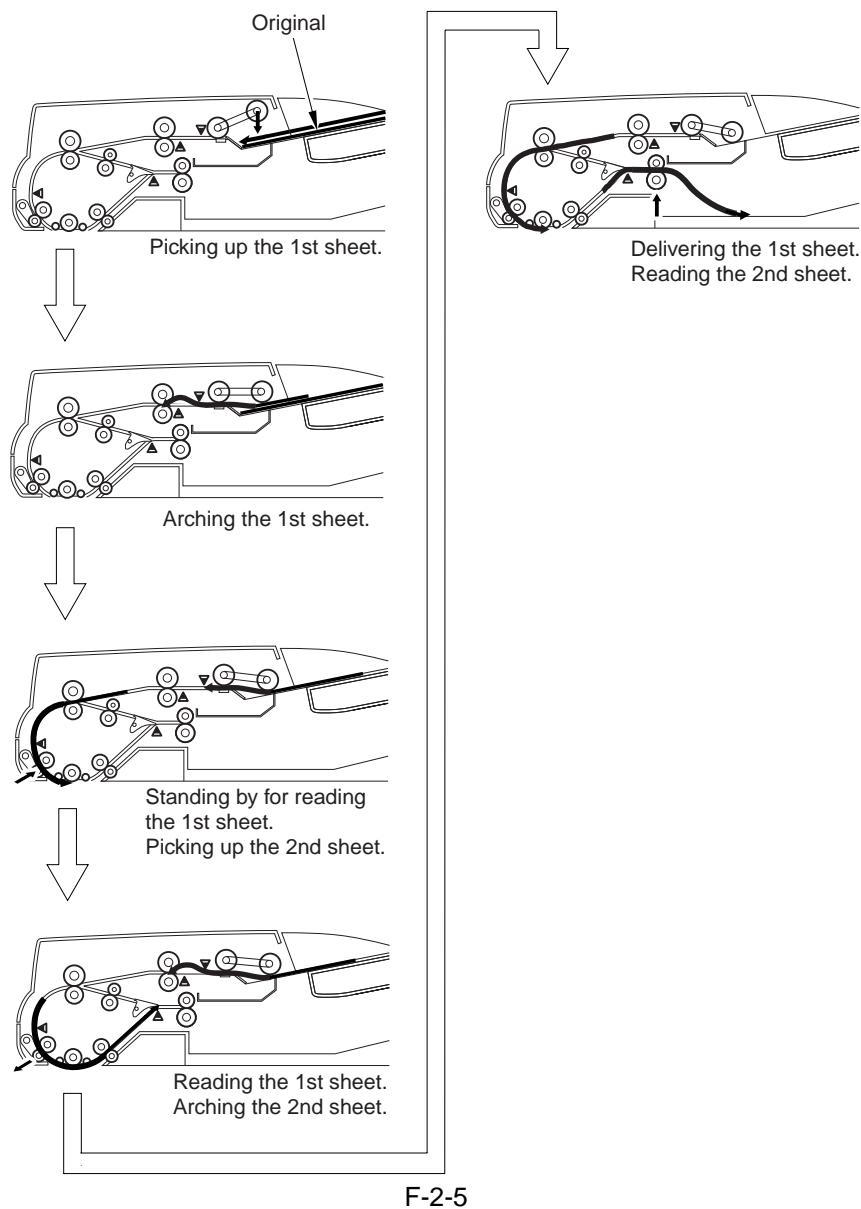

2.2.4 Normal Rotation Pickup/Delivery Operation (double-sided original -> double-sided print)

0002-7298

The following shows the flow of originals:

1. Low speed double-sided mode
a. Small-Size

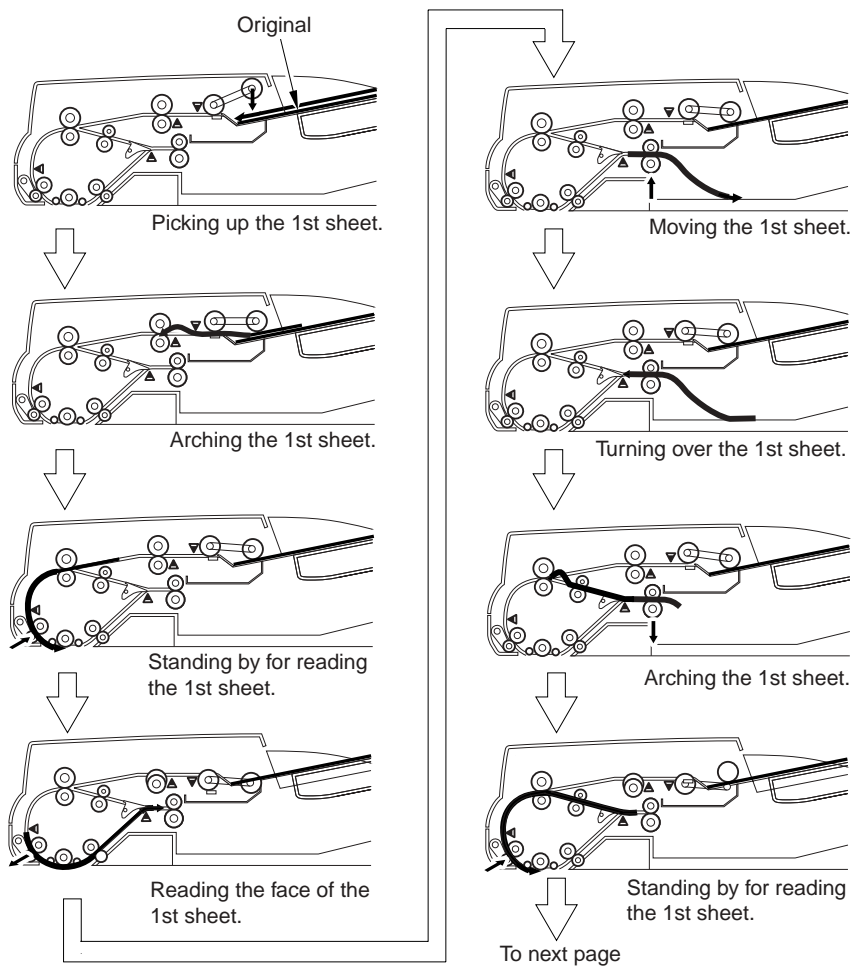

F-2-6

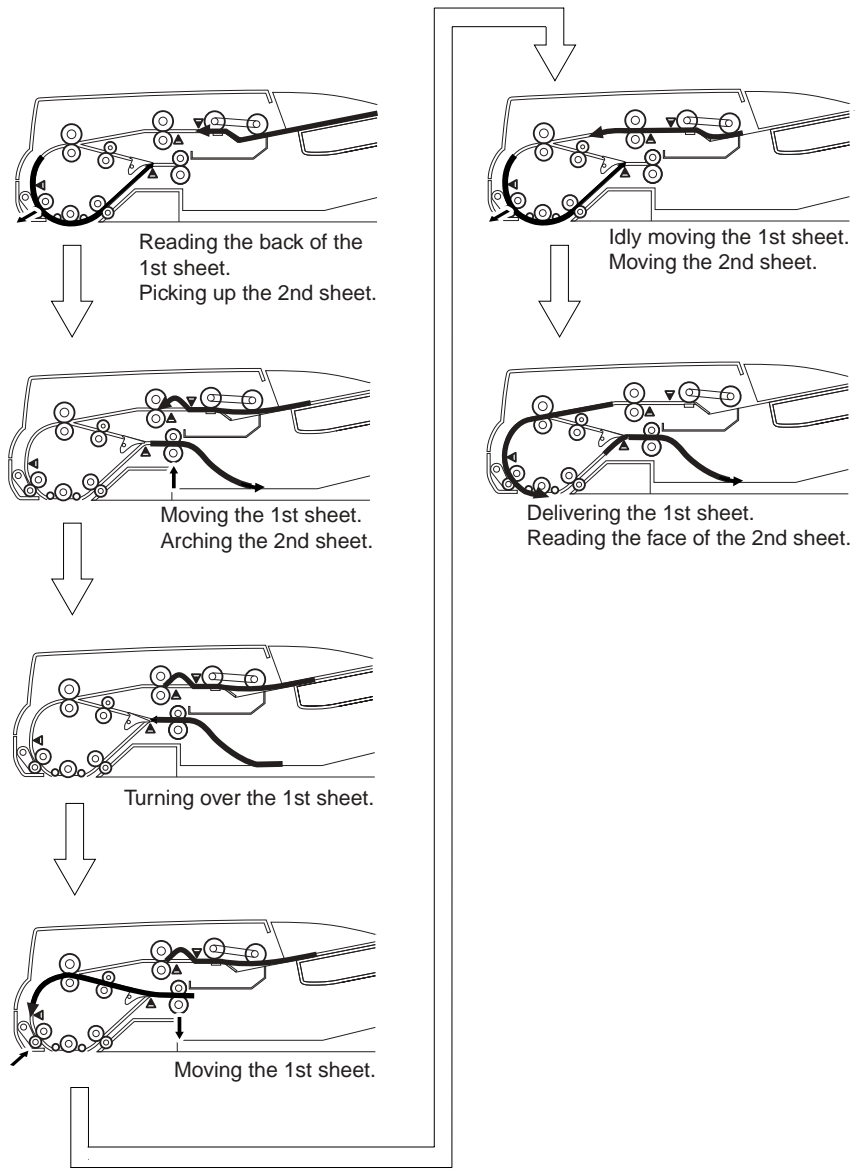

F-2-7

b. Large size

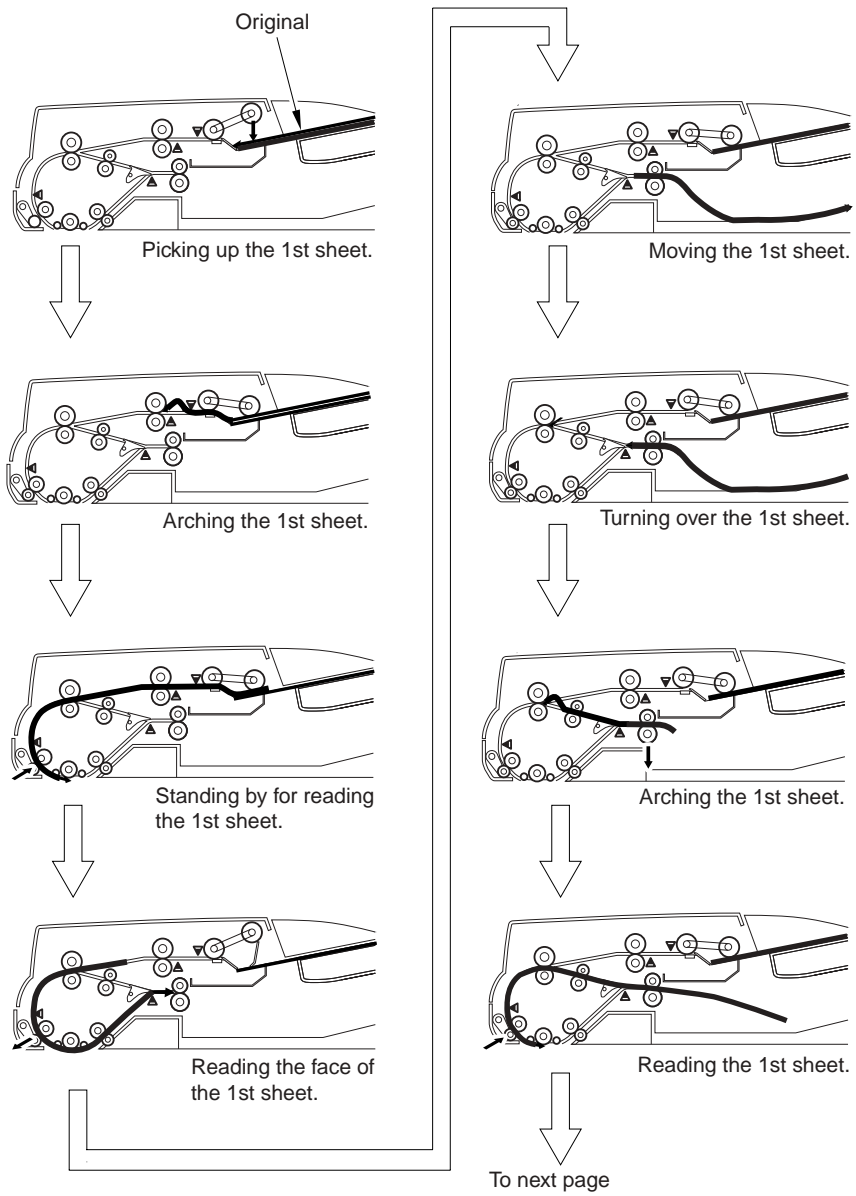

F-2-8

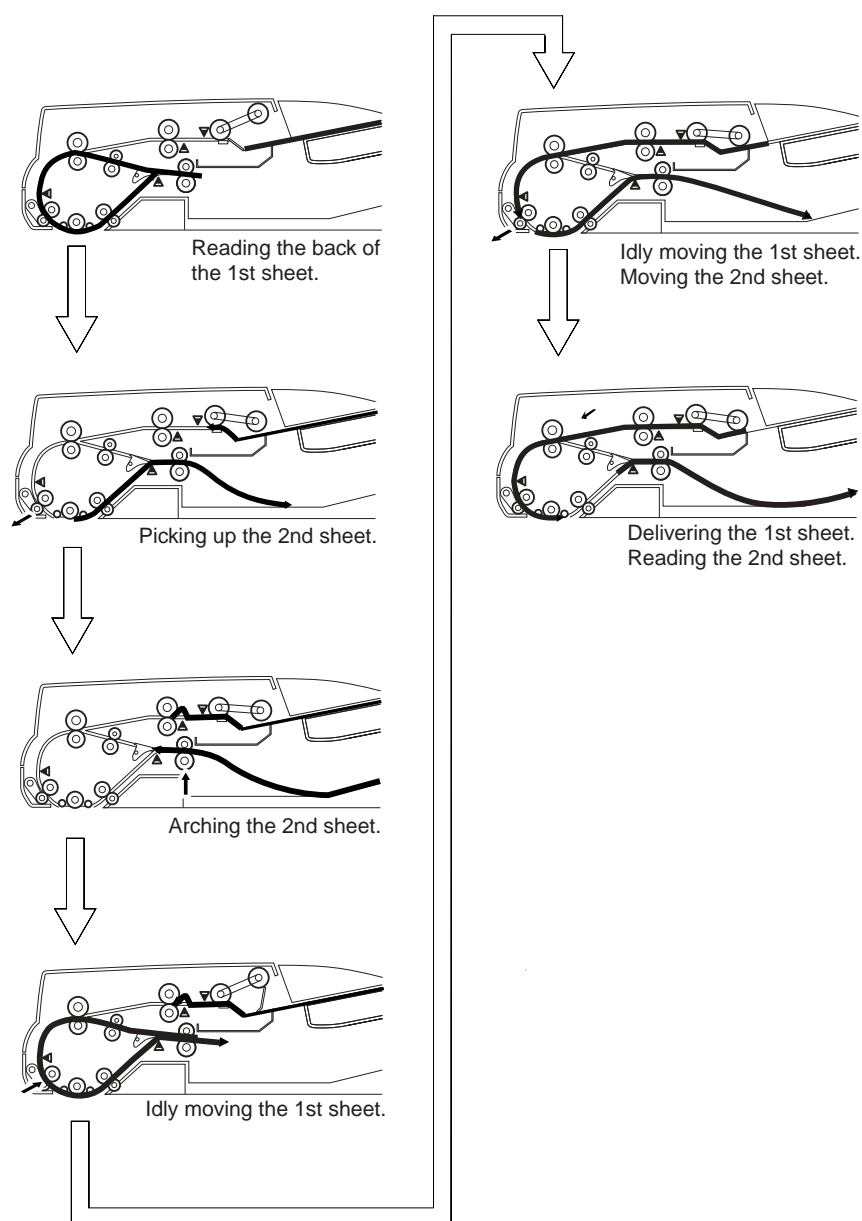

F-2-9

2. High-speed Duplex Mode

In addition to the conventional duplexing operation (face -> back -> idle rotation -> delivery), the machine is equipped with a mechanism referred to as "high-speed duplexing," in which 2 sheets of paper are reversed inside its paper path.

The high-speed duplexing operation is exclusively for A4/LTR, and the machine handles the originals at a speed of 35 ipm (If in low-speed duplexing, 25 ipm).

The high-speed duplexing mechanism may be enabled or disabled in service mode: DISPLAY>FEEDER>OPTION>SL-DBL (0: high-speed duplexing mode (default); 1: low-speed duplexing mode). If the user tends to use originals not suited to high-speed duplexing mode, be sure to select low-speed duplexing mode using the foregoing service mode item. The following shows the flow of originals in high-speed duplexing mode:

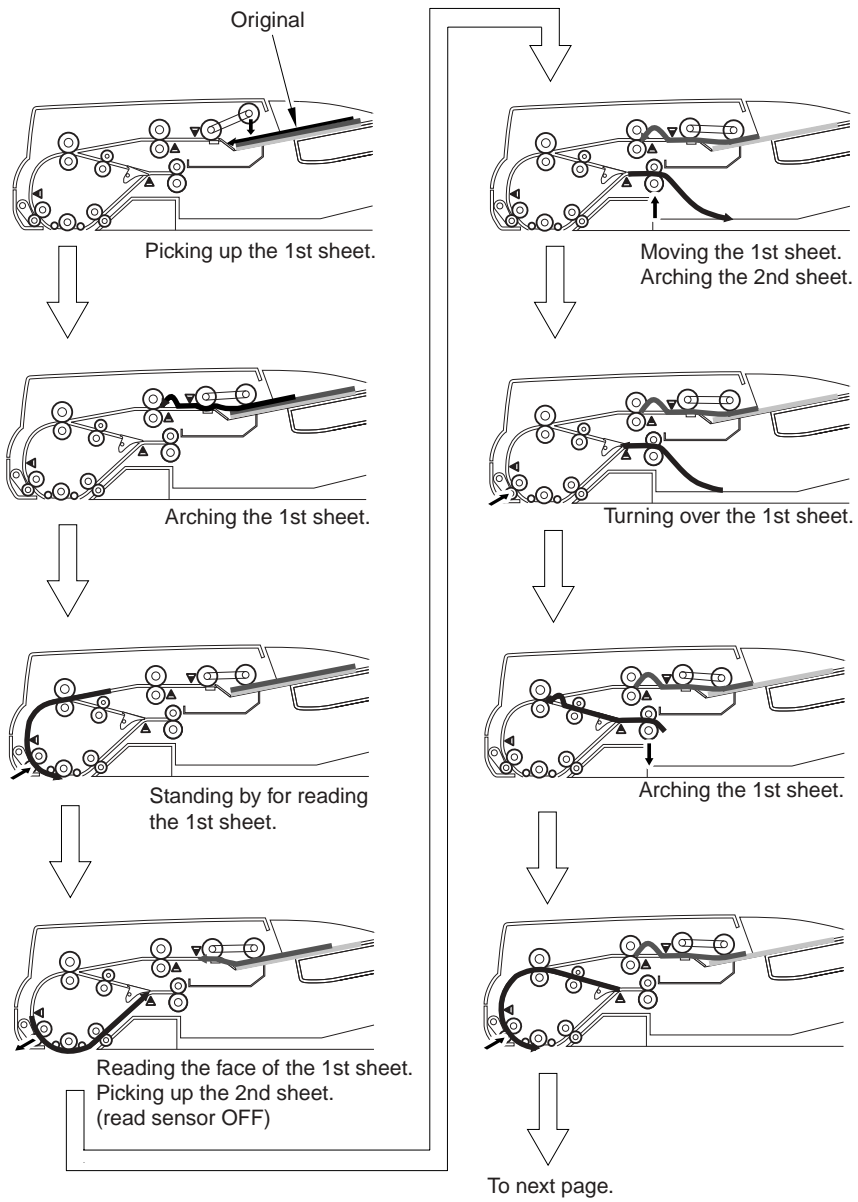

F-2-10

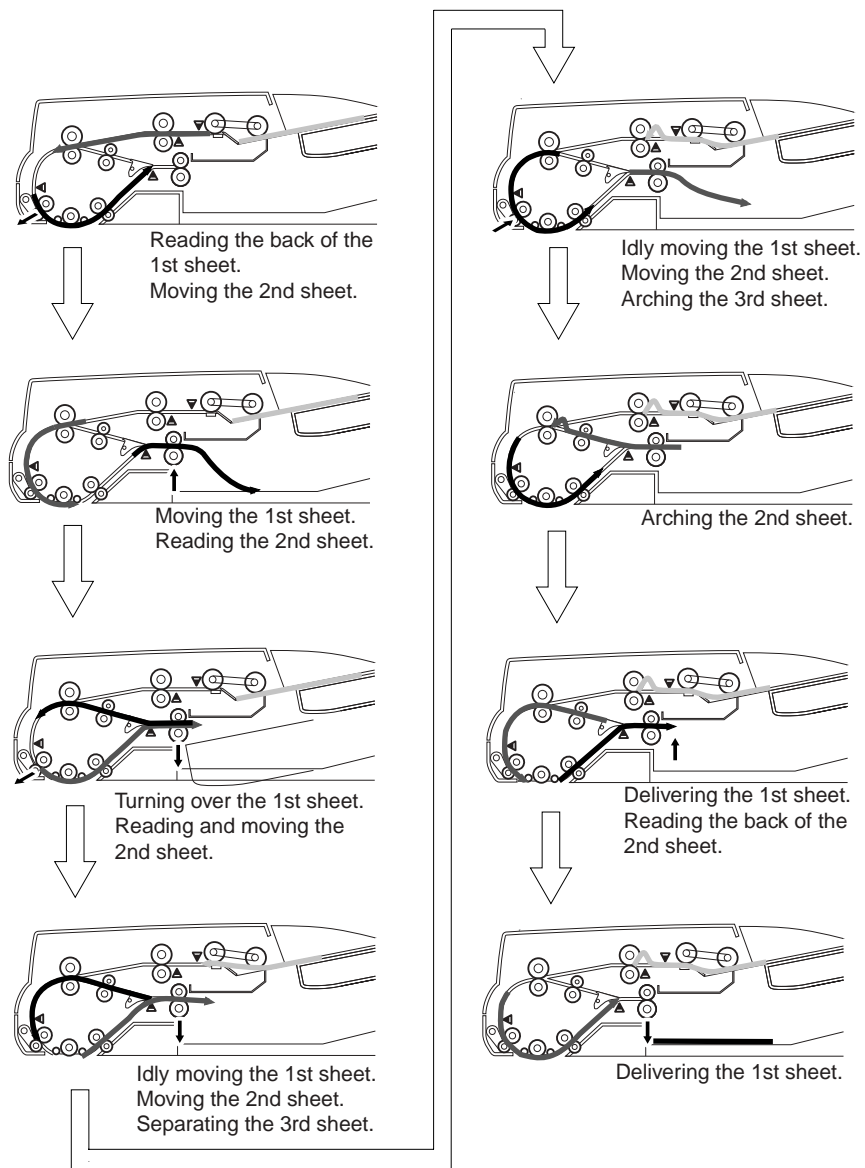

F-2-11

2.2.5 Normal Rotation Pickup/Reversal Delivery (double-died original -
> double-sided print)

0002-7301

The following shows the flow of originals:

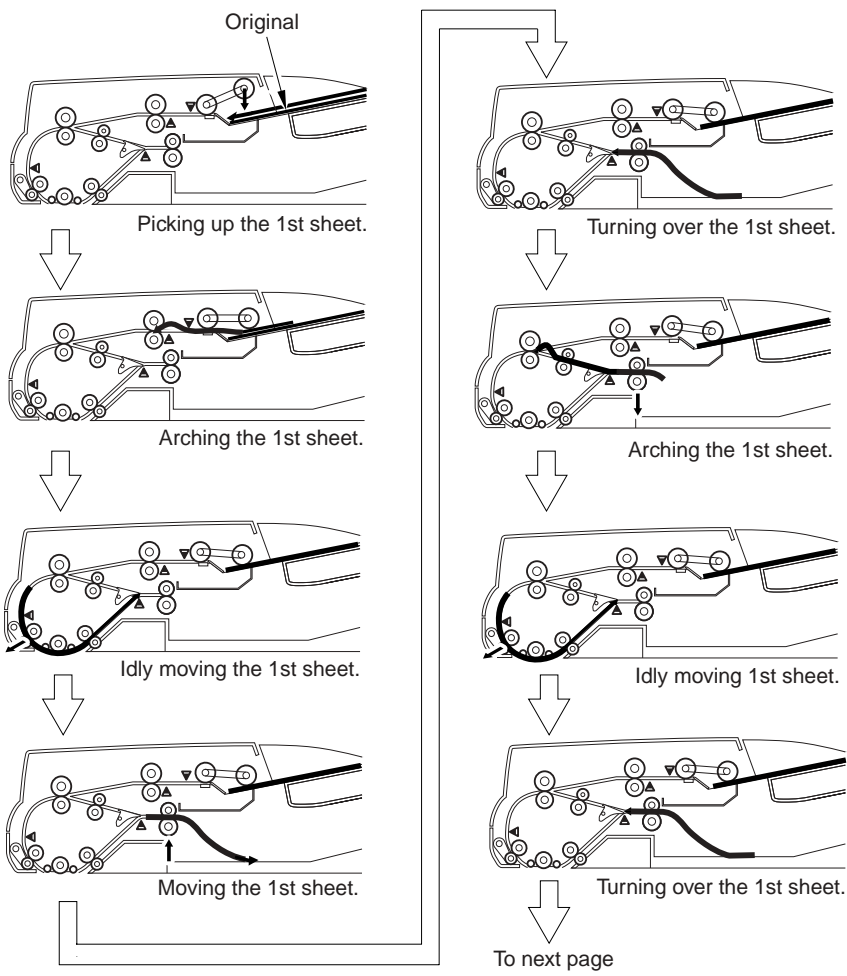

F-2-12

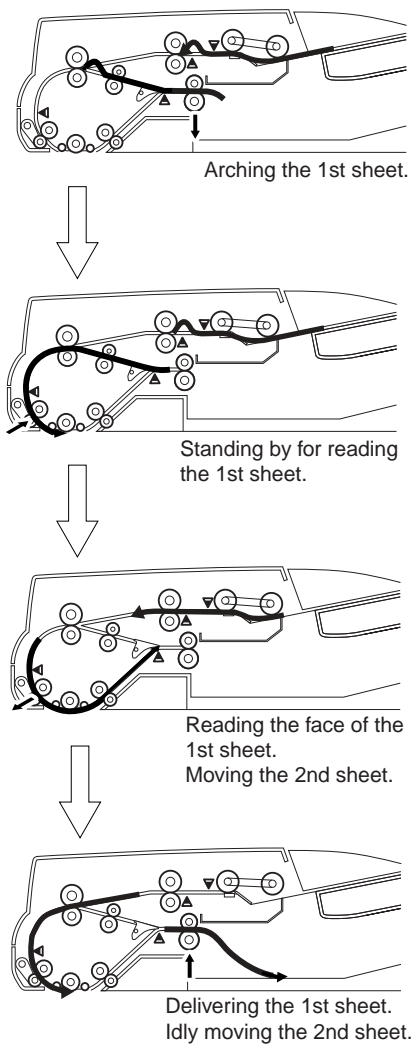

F-2-13

2.2.6 Idle Feed/Reversal Pickup/Delivery (single-sided original of mixed configurations -> single-sided print)

0002-7299

The following show the flow of originals:

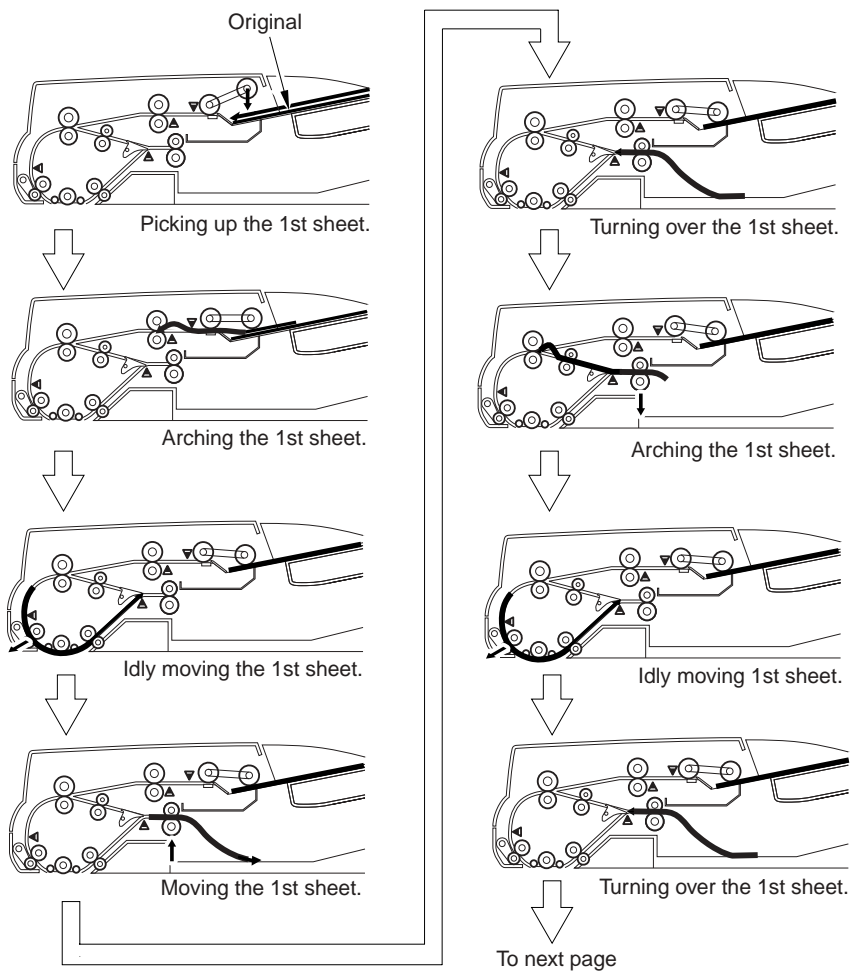

F-2-14

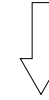
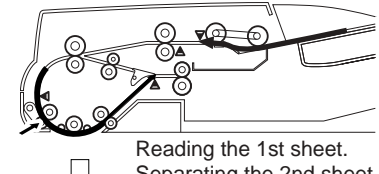
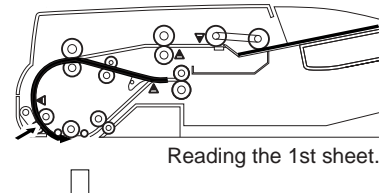
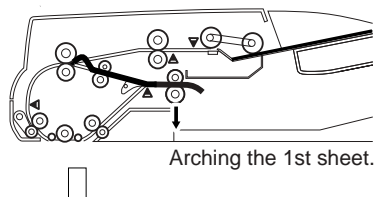
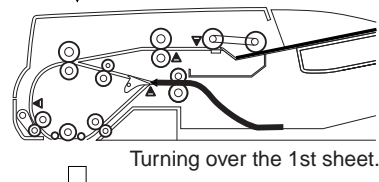
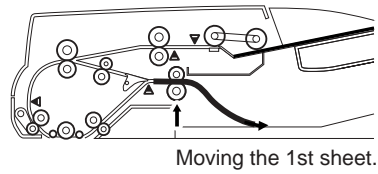
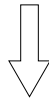
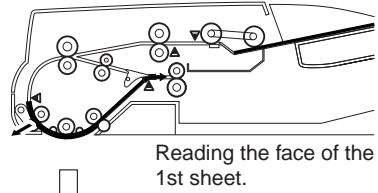
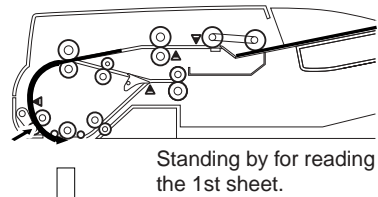
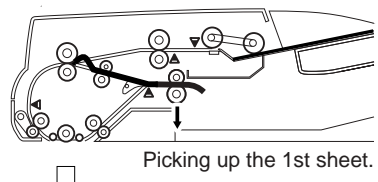

To next page

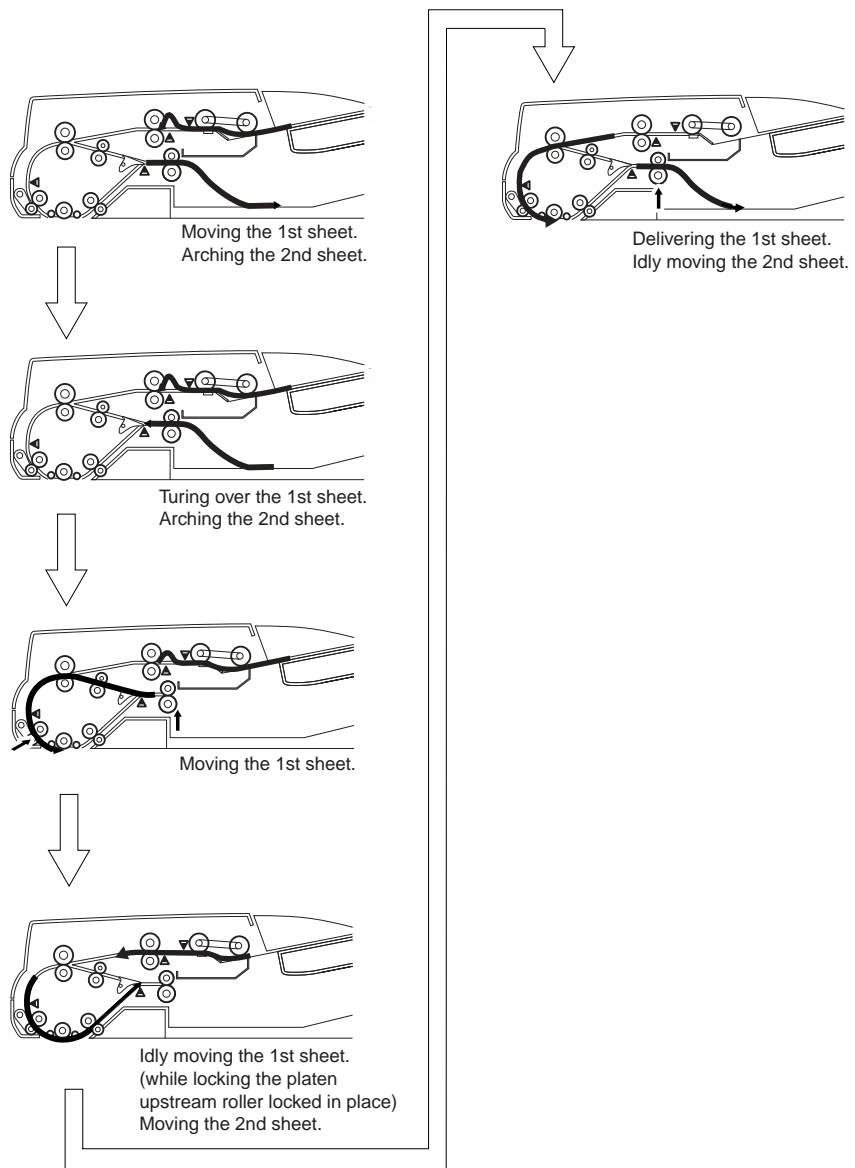

F-2-16

2.3 Document Detection

2.3.1 Overview

0002-7374

The machine possesses the following 2 modes of operation to suit different printing modes:

a. normal mode (other than mix of different configurations or extra-length)

T-2-3

Item	Description	Sensor used (notation)
Presence/absence of original	checks the presence/absence of an original in the original pickup tray.	original placement sensor
Original size identification		
Feed direction	monitors the state of the post-separation sensor (on/off) after the read sensor goes on to identify the original as being small or large.	post-separation sensor, read sensor
	checks the length of the original placed in the original pickup tray; identification of LTR and LGL.	LGL sensor
Cross-feed direction	checks the width of the original placed in the original pickup tray.	original width volume (VR1)
	identification between A4R/A5R and LTRR/STMTR	AB/inch sensor

b. Mix of Different Configurations/Extra-Length

If the originals are of different configurations or are of extra length, the following 3 detection mechanisms are used:

Item	Description	Sensor used (notation)
checks the presence/absence of an original in the original pickup tray.	checks the presence/absence of an original in the original pickup tray.	original placement sensor (PI5)
Original presence/absence		
Cross-feed direction	checks the width of the original placed in the original pickup tray.	original width volume (VR1)
Feed direction	checks the length of the original with reference to the time (distance) from when the read sensor goes on to when it goes off.	read sensor (PI8)

2.3.2 Checking the Presence/Absence of an Original

0002-7429

The machine uses the original placement sensor (PI5) to check the presence/absence of an original in the original tray.

When an original is placed on the tray, the detecting lever operates in conjunction with the light-blocking plate, during which the light-blocking plate blocks the light of the photo interrupter. As a result, the original placement sensor (PI5) generates the original detection signal (EMP_S), which will cause the ADF driver PCB to turn on the original placement indicator.

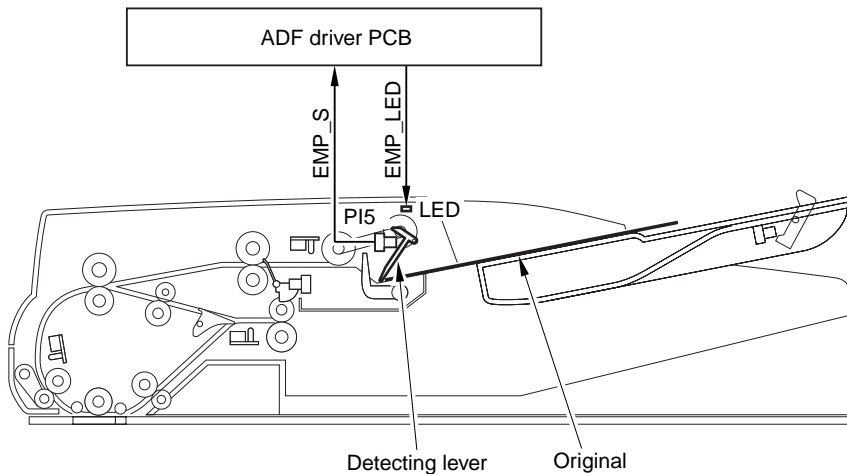

F-2-17

2.3.3 Identifying the Size of the Original

0002-7466

A. Normal Printing

The machine identifies the size of an original with reference to combinations of the size (width, length) detected on the original tray and the size (length) detected while the original is being moved.

a. Detecting the Size of the Original in Feed Direction

The machine detects the size of an original in feed direction with reference to the state of the post-separation sensor (PI7) after the read sensor (PI8) has gone off and the state of the LGL sensor (PI4) on the tray (LGL/STMT).

The machine measures the length of the time from when the read sensor goes on to when it goes off to find out the length of the original; it then uses the result of the measurement and the result of detection made on the original tray to identify the size of the original.

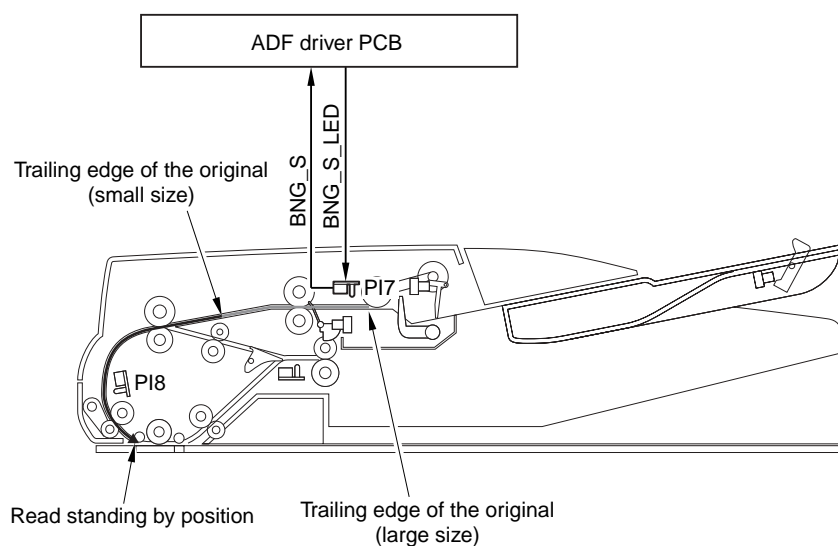

F-2-18

When an original is placed on the original tray, the light-blocking plate operates in keeping with the detecting lever of the LGL sensor to block the light of the photo interrupter. The machine identifies whether or not the original is LGL with reference to the LGL sensor signal (LG_S) and the width of the original. The machine communicates the original size information to the host machine as soon as the Start key is pressed.

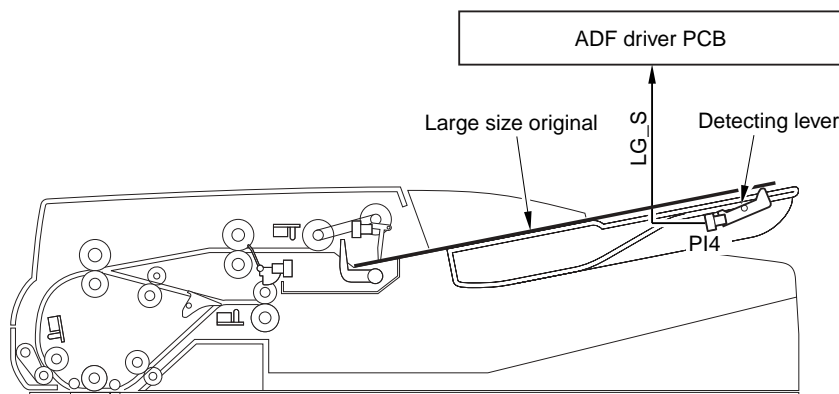

F-2-19

b. Detecting the Size of the Original in Width Direction.

The width of an original is detected using the original width detecting volume (VR1) found inside the original tray. The volume operates in conjunction with the slide guide, its resistance changing (analog) as the slide is moved. The ADF driver PCB reads these changes in resistance as the original size signal (WIDTH), and recognizes them as specific widths.

To make sure that the original width volume (VR1) correctly detects A4R/LTRR and A5R/STMT widths, a special AB/inch sensor (PI4) is used inside the original tray; the sensor goes '1' (AB/inch identification signal) when the width of the original is 197 mm or more and less than 214 mm.

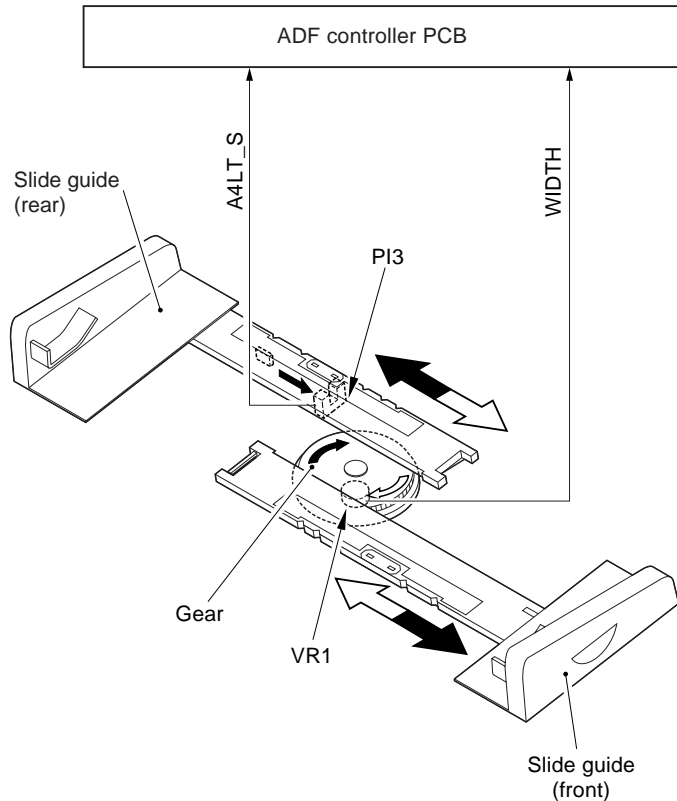

F-2-20

The track of the slide guide is given a groove so that the slide may stop at specific default sizes. Some sizes, however, are extremely close to each other, possibly causing the slide to stop at the wrong point. To make sure that the slide stops at the correct stops, the slide is provided with a positioning roll [1], which restricts the stops as follows:

T-2-5

Marking on slide guide positioning roll	Slide guide stop position	
	Side with 1 groove	Slide with 2 grooves
A4R	A4R	A4R LTRR

Marking on slide guide positioning roll	Slide guide stop position	
	Side with 1 groove	Slide with 2 grooves
INCH	LTRR	A4R LTRR

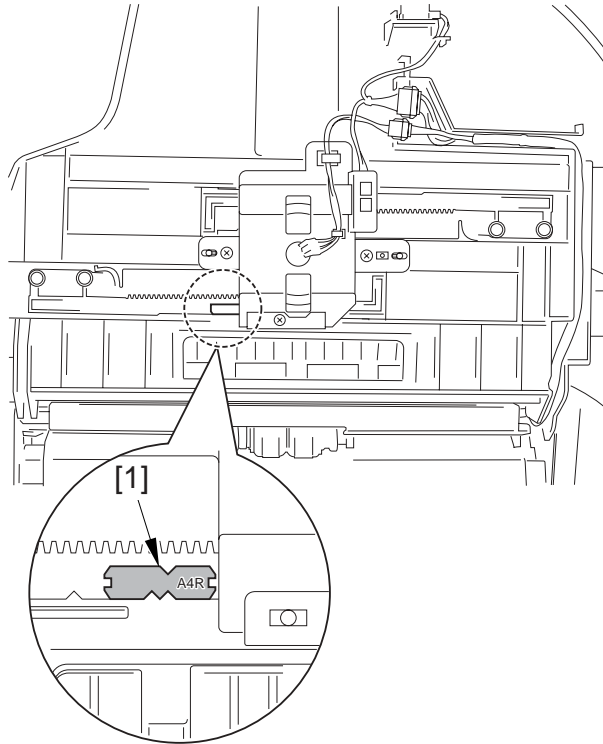

F-2-21

B. Mix of Different Configurations, Extra-Length

The machine measures the length of time (distance) from when the read sensor goes on to when it goes off; it then uses the result of the detection (length) and the result of detection made on the original tray to identify the size of the original.

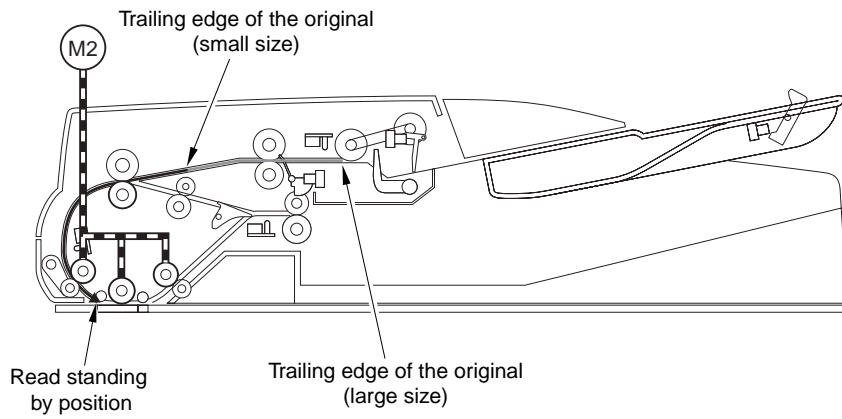

F-2-22

The following is a list of the default sizes that are recognized in relation to different printing modes:

a. Normal Mode

Inch-Configuration

T-2-6

Width (volume; mm)	A4R/ INCH sensor	Post- separatio n sensor	LGL sensor	Detection size (AB)
width>289		ON OFF		A3 A4
289>/= width>269		ON OFF		A3 A4
269>/= width>247		ON OFF		B4 B5
247>/= width>200		ON OFF		A4R A5
200>/= width>172		ON OFF		B5R B6
172>/= width		OFF		A5R

Inch-Configuration

T-2-7

Width (volume; mm)	A4R/INCH sensor	Post- separatio n sensor	LGL sensor	Detection size (inch)
width>289		ON OFF		12×18 LTR
289>/=width >269		ON OFF		LDR LTR
269>/=width>247		ON OFF		LDR LTR
247>/= width>200		ON ON OFF	ON OFF	LGL LTRR STMT
200>/= width>172		ON ON OFF	ON OFF	LGL LTRR STMT
172>/=width				STMTR

* LDR:11×17

AB/Inch-Configuration

T-2-8

Width (volume; mm)	A4R/ INCH sensor	Post- separati on sensor	LG L sens or	Detection size (AB/ inch mix)
width>289		ON OFF		A3 A4
289>/ =width>269		ON OFF		LDR LTR
269>/=width >247		ON OFF		B4 B5

Width (volume; mm)	A4R/ INCH sensor	Post- separati on sensor	LG L sens or	Detection size (AB/ inch mix)
247>/= width>200	ON ON OFF OFF OFF	ON OFF ON ON OFF	ON OFF	A4R A5 LGL LTRR STMT
200>/ =width>172		ON OFF		B5R B6
172>/= width	ON OFF	OFF OFF		STMTR A5R

b.Mix of Same Width

The machine executes LGL/LTRR identification by idly circulating the original only if it has detected that the original on the tray is LGL at the start of operation; otherwise, the foregoing tables will be followed:

The machine identifies the original on the tray as being LGL for the following conditions:

T-2-9

	LGL sensor	
247>/= width>200	ON	LGL
	OFF	LTRR

The following conditions are used for making the final decision:

T-2-10

length>318	LGL
318>/ =width>248	LTRR
248>/=length	STMT

c.Mix of Different Configurations

Mix of AB Configurations

T-2-11

Length (mm)	Width (mm)	A4RE/ INCH sensor	LGL sensor	Post- separati on sensor	Detection size (AB)
length>392					A3
392>=length>331					B4
392>=length>277					A4R
277>=length>234					B5R
234>=length>196	Width> 269 269>/ =Width				A4 A5R
196>=length>165					B5
165>=length>138					A5
138>=length					B6

MEMO

B5R, A5R, and B6 are outside the scope of specifications.

Mix of Inch Different Configurations

T-2-12

Length (mm)	Width (mm)	AB/ INCHsens or	LGLse nsor	LGL sensor	Detection size (inch)
Length>394	Width>28 9				12×18 LDR
394>/ =Length>318					LGL
318>/ =Length>248					LTRR

248>/ =Length>178	Width>24 7 247>/ =Width				LTR STMTR
178>/=Length					STMT

MEMO

B5R, A5R, and B6 are outside the scope of specifications.

2.4 Document Pickup/Separation

2.4.1 Basic Sequence of Operation

0002-9454

When the Start key is pressed with an original on the original tray, the machine executes the following sequence of operation to pickup up the original:

a. Picking Up the Original

When the pickup motor (M1) rotates in reverse and the pickup clutch (CL1) goes on, the pickup roller unit moves down to start pickup operation. The separation plate and the separation pad are used to prevent multiple feeding of originals. (After the 2nd original, the pickup unit remains in down position.)

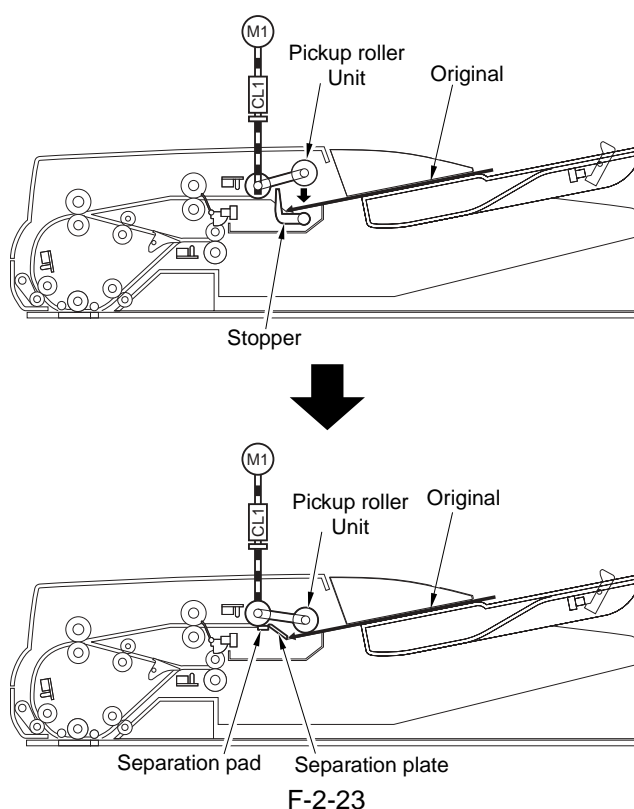

b. Arching the Original

When the original has been moved for a specific number of pulses after the registration sensor has gone on, the original is caused to arch at the No. 1 registration roller so that it becomes free of any skew.

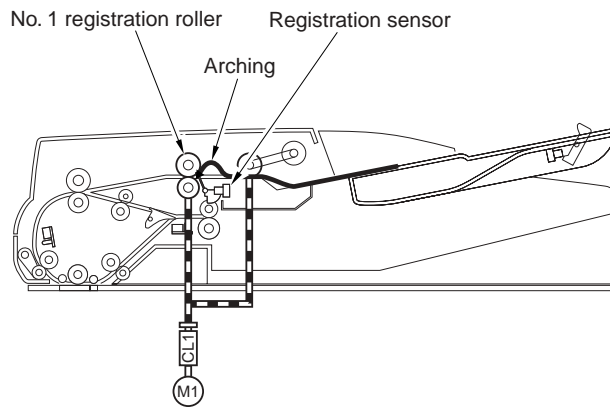

F-2-24

c. Sheet-to-Sheet Distance

While the original is between the No. 1 registration roller and the No. 2 registration roller, its movement is accelerated so that there will be a sheet-to-sheet distance at the time it reaches the No. 2 registration roller for reading. The normal rotation maximum speed of the pickup motor is 750 mm/sec; it decelerates to reading speed at a point 23 mm in front of the No. 2 registration roller to move the original to the No. 2 registration roller.

d. Moving the Original

The pickup clutch goes off and the pickup motor rotates in normal direction to move the original. The lock motor is driven for locking before the leading edge of the original reaches the platen upstream roller (thereby preventing the shock otherwise occurring when the trailing edge of the original leaves the roller). When the original reaches the point of deceleration before reading, the machine checks whether the READY signal is on, in which case it will move the original ahead to the point of reading; if the signal is off, the machine keeps the original in wait for reading. (In the case of the 1st original, the machine moves it as far as the read sensor at 650 mm/sec.)

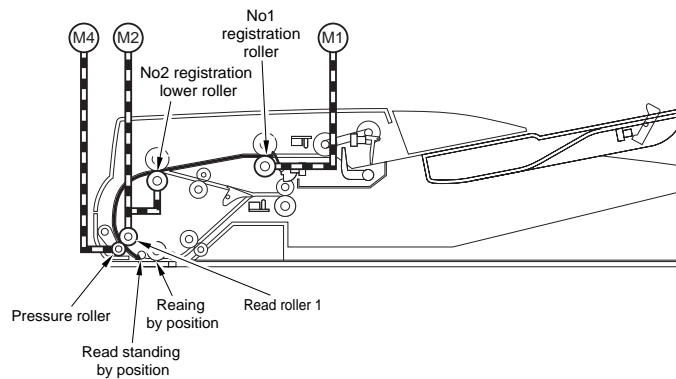

F-2-25

e. Stream Reading

The machine identifies the point of reading with reference to the pulses generated by the read motor after the read sensor goes on. When the leading edge of the original reaches the point of reading, the machine sends the image leading signal to the host machine so that the latte can start reading operation.

In stream reading mode, the scanner of the host machine is fixed in place, and the original is scanned while it is being moved over the reading glass. The images that are read are stored in the memory of the host machine.

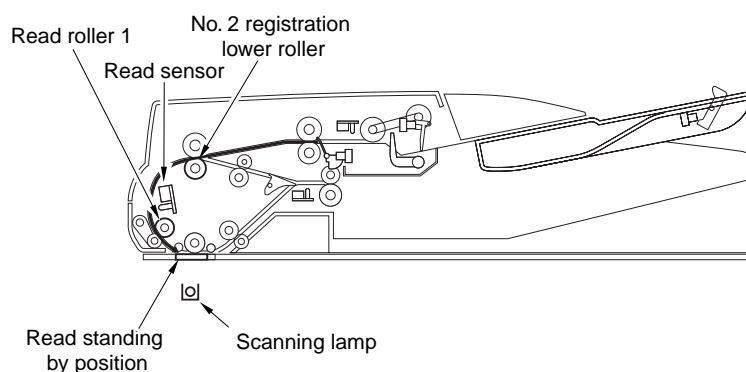

F-2-26

2.4.2 Pickup Unit and the Stopper

0002-9493

The pickup unit consists of a pickup roller and a separation roller. When the Start key is pressed or the original pickup signal arrives, the pickup motor (M2) starts to rotate in reverse to move down the pickup unit, and the pickup roller and the separation roller start to rotate to pick up an original. The separation pad and the separation plate are used to make sure that no more than one original is picked up and fed at time of pickup.

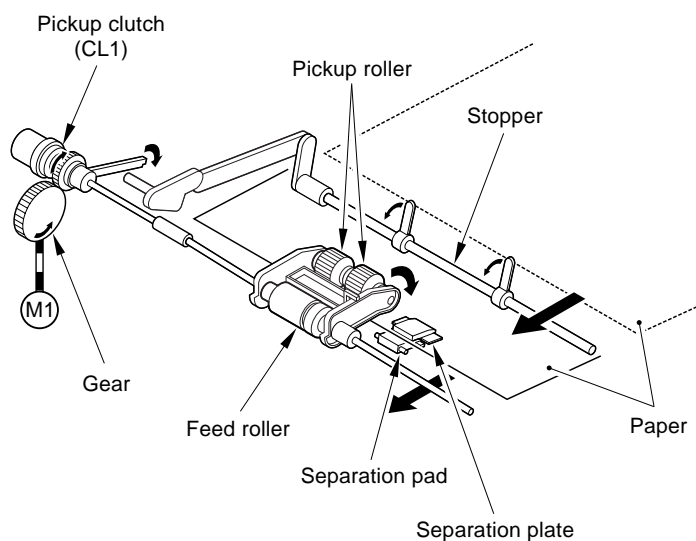

F-2-27

2.4.3 Timing of Pickup

0002-9495

Sequence of Pickup Operation (small-size)

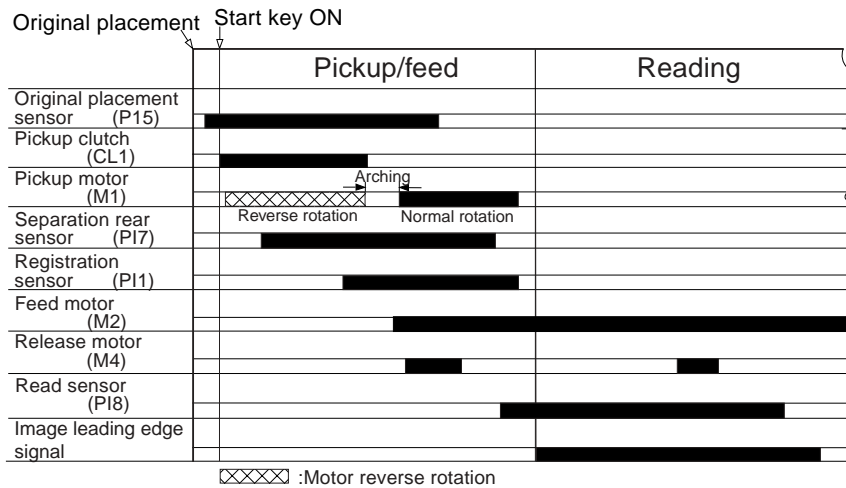

F-2-28

2.4.4 Controlling the Pickup Motor (M1)

0002-9497

The following is a diagram of the circuit used to control the pickup motor (M1). The pickup motor is a 4-phase stepping motor, and the circuit serves the following functions:

- turning on/off the motor
- controlling the rotation direction of the motor
- controlling the rotation speed of the motor

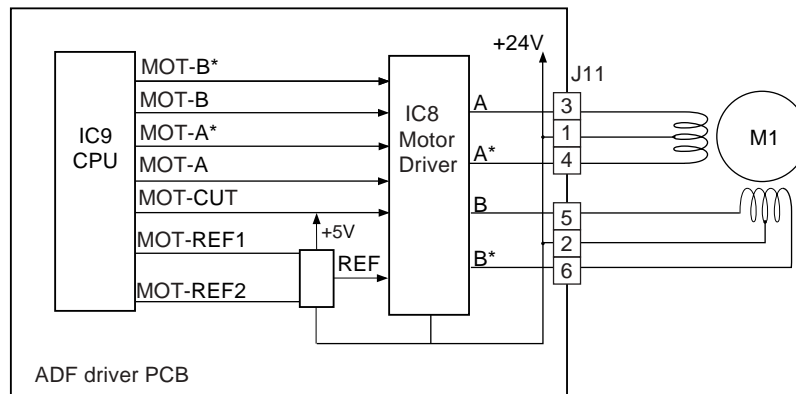

F-2-29

IC9 on the ADF driver PCB receives print data (command) on printing mode from the host machine (magnification, operation mode, timing); in response, it generates drive pulses to drive the pickup motor.

The pickup motor (M1) is a stepping motor, and its direction and speed of rotation are varied by changing the order and the frequency of drive pulses (A, A*, B, B*).

2.4.5 Controlling the Lock Motor (M4)

0003-6080

The following is a diagram of the circuit used to control the lock motor, and the circuit has the following function:

- turning on/off the motor
- controlling the speed of motor rotation

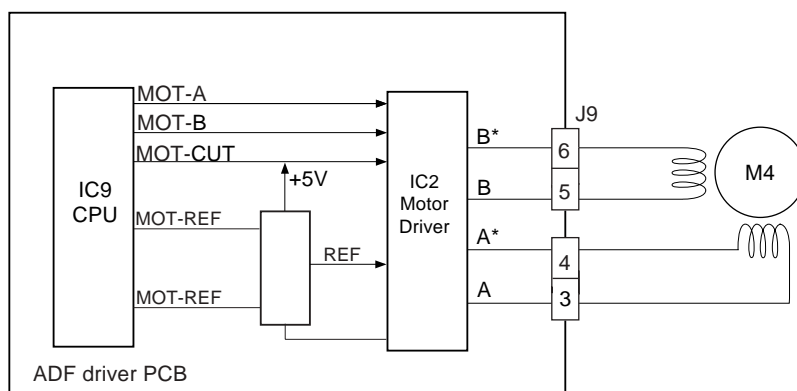

F-2-30

IC9 on the ADF driver PCB receives data (command) from the host machine on printing mode (magnification, operation mode, timing); in response, it generates drive pulses to drive the lock motor.

The lock motor (M4) is a stepping motor, and the direction and speed of its rotation are changed by changing the order and frequency of drive pulses (A, A*, B, B*).

2.5 Document Reversing

2.5.1 Basic Sequence of Operation

0002-9742

a. Picking Up the Original for Reading the 1st Side

The platen roller rotates using the drive from the feed motor (M2) for reading the 1st side of the original. The machine keeps count of pulses from the feed motor to monitor the movement of the original; and, before the trailing edge of the original leaves the platen upstream roller, the machine drives the lock motor (M4) for a specific number of pulses to move the platen upstream roller away (i.e., to prevent the impact otherwise occurring when the trailing edge of the original leaves the roller). Moreover, before the trailing edge of the original leaves the platen downstream roller, the machine turns on the delivery reversal motor (M3) to discharge the original; likewise, it also turns on the release solenoid to lock the delivery reversing roller in place. The machine accelerates the delivery reversal motor when the trailing edge of the original leaves the platen downstream roller.

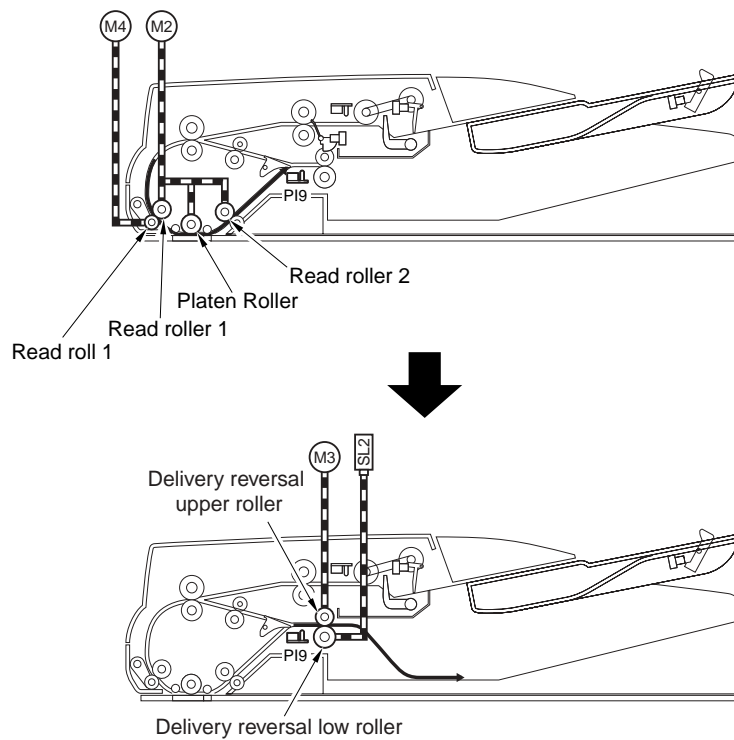

F-2-31

b. Reversing/Feeding the Original 1

The delivery reversal motor (M3) stops when the trailing edge of the original moves past the delivery reversal sensor (PI9); immediately thereafter, the delivery reversal motor (M3) starts to rotate in reverse so that the original will arch against the No. 2 registration roller. At the same time, the locking solenoid goes off to move the delivery reversing roller away.

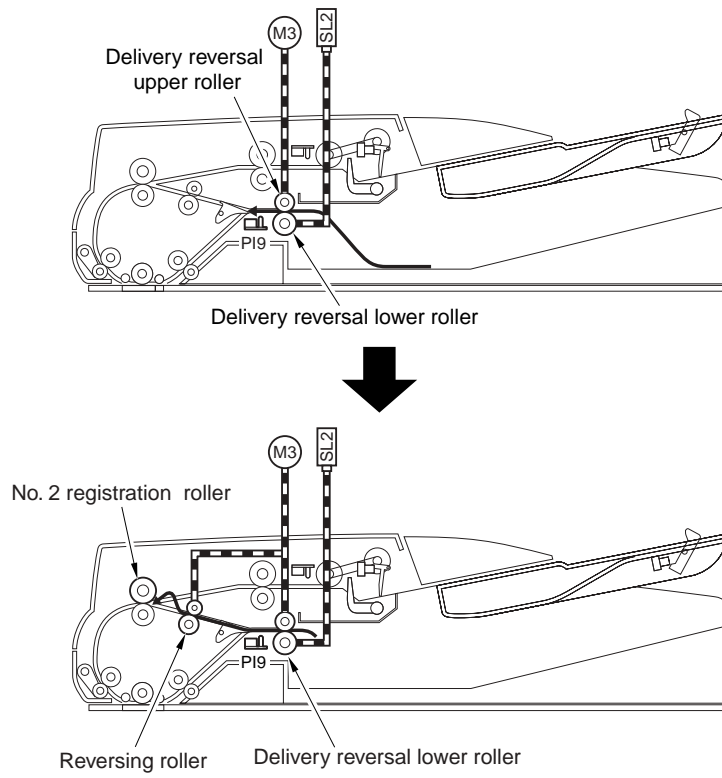

F-2-32

c. Reversing/Moving the Original 2

The machine rotates the feed motor in normal direction and the delivery reversal motor in reverse to move sheets at the same time. The machine stops the delivery reversal motor when the originals have moved a specific distance. The machine then drives the lock motor for a specific number of pulses to lock the platen upstream roller in place.

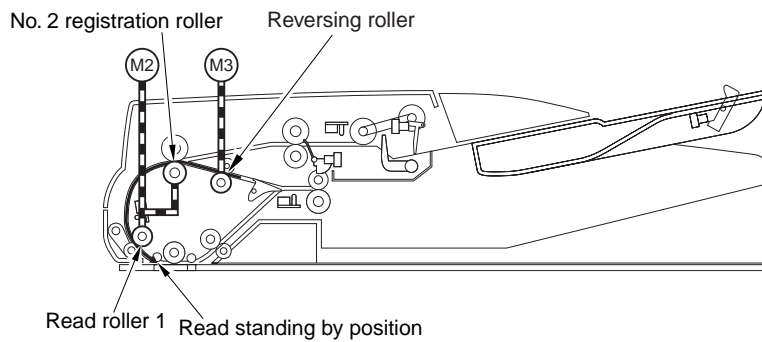

F-2-33

2.5.2 Sequence of Operation

0002-9821

Sequence of Operation (small-size, reversal)

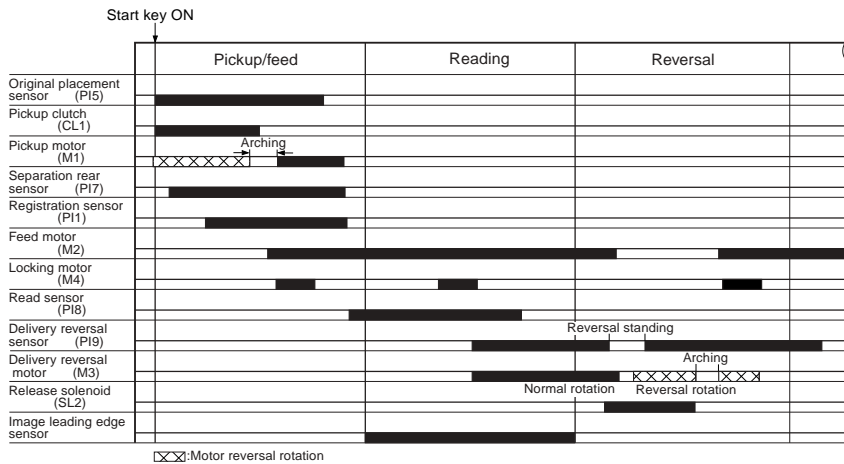

F-2-34

2.5.3 Controlling the Delivery Reversal Motor (M3)

0002-9898

The following is a diagram of the circuit used to control the delivery reversal motor (M3). The delivery reversal motor (M3) is a 4-phase stepping motor, and the circuit has the following functions:

- turning off/on the motor
- controlling the rotation direction of the motor
- controlling the rotation speed of the motor

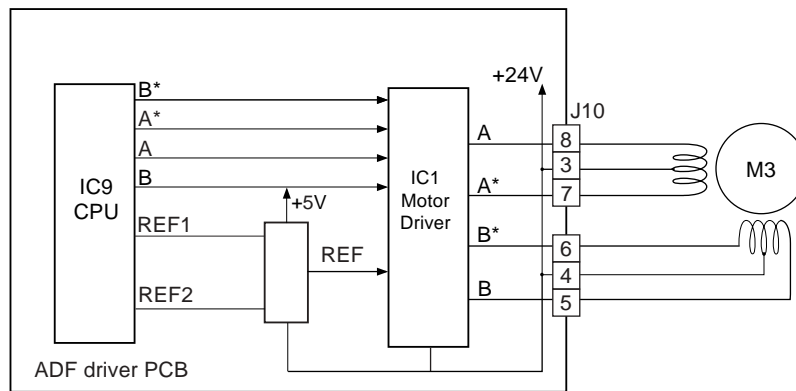

F-2-35

The CPU (IC4) on the ADF driver PCB receives data (command) from the host machine on print mode (magnification, operation mode, timing); in response, it generates drive pulses to drive the delivery reversal motor (M3). The delivery reversal motor (M3) is a stepping motor, and the direction and speed of rotation are changed by changing the order and frequency of drive pulses (A, A*, B, B*).

2.6 Document Feeding/Delivery

2.6.1 Basic Sequence of Operation

0002-9828

a. Moving the Originals

The machine turns on the locking solenoid before the trailing edge of the original leaves the platen downstream roller to lock the delivery reversing roller in place. It then accelerates the delivery reversal motor when the trailing edge of the original leaves the platen downstream roller for delivery.

The machine uses the following sequence of operation to deliver the original when the host machine finishes reading it:

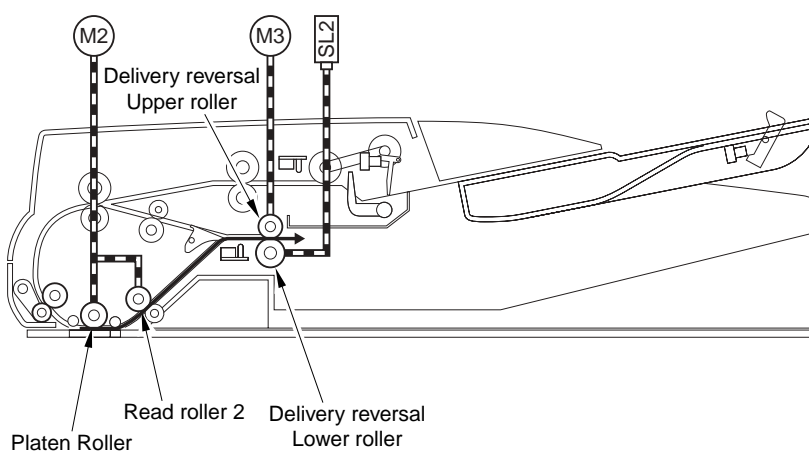

F-2-36

b. Delivering to the Original Delivery Assembly

The original is moved to the original delivery assembly by the delivery reversing roller, which rotates when the delivery reversal motor (M3) rotates in normal direction.

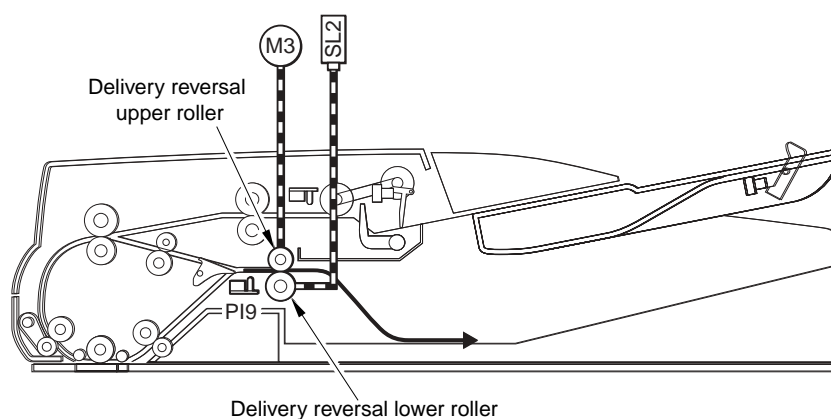

F-2-37

2.6.2 Sequence of Operation

0002-9872

Sequence of Operation (small-size, delivery)

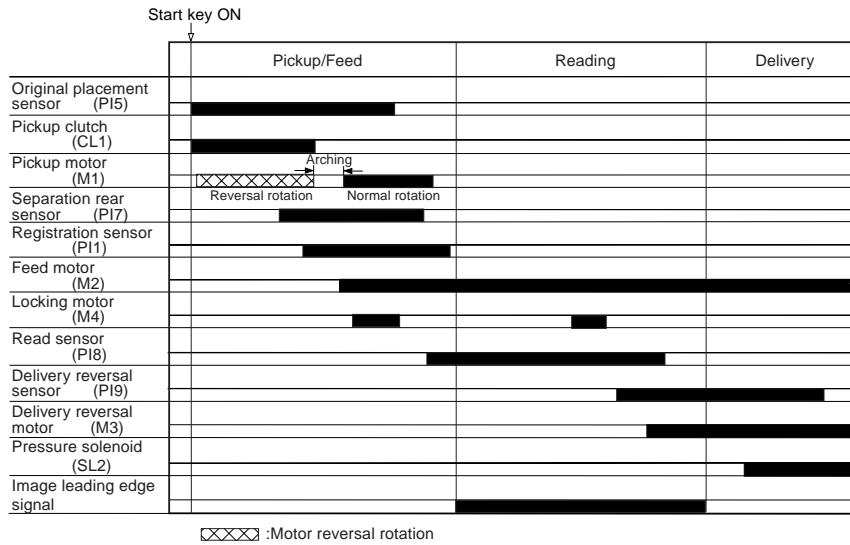

F-2-38

2.6.3 Controlling the Feed Motor

0002-9874

The following is a diagram of the circuit used to control the feed motor (M2). The feed motor (M2) is a 4-phase stepping motor, and the circuit has the following functions:

- turning on/off the motor
- changing the rotation direction of the motor
- changing the rotation speed of the motor

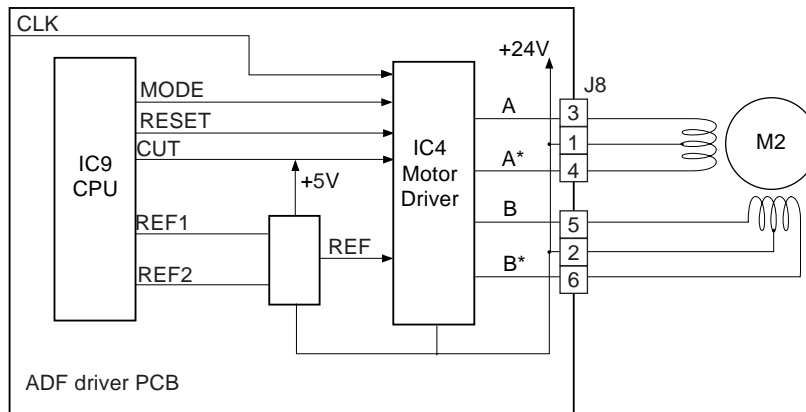

F-2-39

The CPU (IC9) on the ADF driver PCB receives data (command) from the host machine on printing mode (magnification, operation mode, timing); in response, it generates drive pulses to drive the feed motor (M2). The feed motor (M2) is a stepping motor, and its direction and speed of rotation are changed by changing the order of drive pulses (A, A*, B, B*).

2.7 Detecting Jams

2.7.1 JAM

0004-5590

The machine checks for an original jam using the sensors shown in the figure. The timing at which a check is made is programmed in the ROM on the reader controller PCB, and the presence/absence of a jam is identified in terms of whether there is paper over a particular sensor.

when it detects a jam, it communicates the fact to its host machine using a code, which may be checked in the host machine's service mode.

-Service Mode Screen of the Host Machine

Display	I/O	Adjust	Function	Option	Test	Counter
< JAM >		< 1/7 >		< READY>		
No.	DATE	TIME1	TIME2	L	CODE	P CNTR SIZE
01	1031	1653	1653	1	0001	1 9399 A4
02	1030	1921	1923	0	0A11	0 0 -----
03	1030	1748	1748	1	0042	2 2515 A4
04	1030	1152	1152	1	0005	1 8668 A4
05	1029	1810	1813	0	010D	1 8096 A4
06	1029	1755	1756	0	0A08	0 0 -----
07	----	----	----	-	----	- ----
08	----	----	----	-	----	- ----

F-2-40

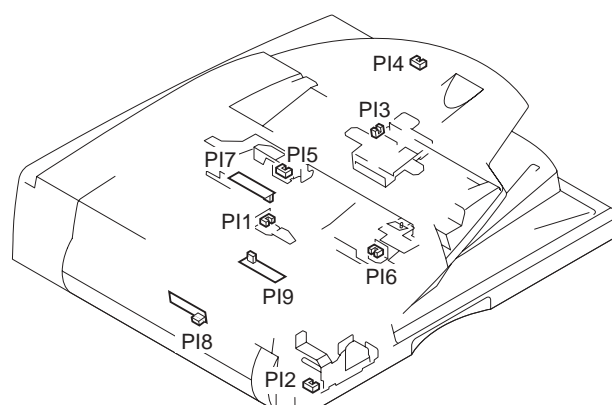

F-2-41

2.8 Power Supply

2.8.1 Power Supply

0002-9917

The following is a diagram of the power supply system of the machine.

The machine is supplied with 2 types of power by the host machine 24 V and 13 V. The 24-V power is mainly used to drive loads (motor, clutch, solenoid), while the 13-V power is converted into 5 V by IC10 (DC-DC converter) for use by sensors and the ADF controller PCB.



Unlike other models, the machine will remain supplied with power even when its feeder cover is opened.

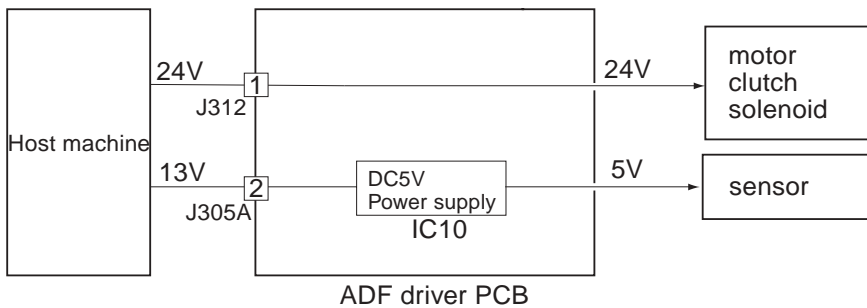

F-2-42

2.9 Stamp Operation

2.9.1 Overview

0003-7021

When the host machine is in fax mode and its stamp function is selected, the machine will put a stamp in response to a command from the ADF drive PCB to indicate that the original in question has been read or transmitted.

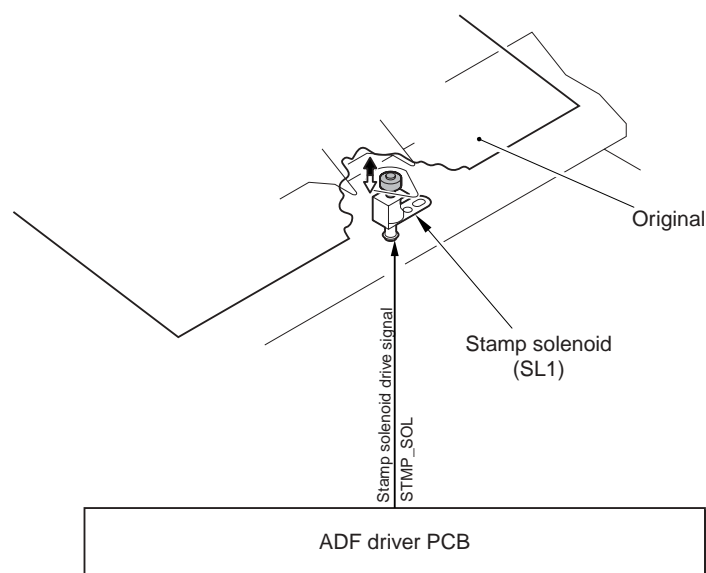

F-2-43

When the trailing edge of the original leaves the platen downstream roller and has moved ahead 3 mm, the machine accelerates the delivery reversal motor from reading speed to 650 mm/sec; on the other hand, it starts to decelerate the motor when the trailing edge of the original is at a point 47.1 mm from the platen downstream roller (from 650 mm/sec) for stopping the original. The machine holds the original in place for 100 msec, during which it turns on the stamp solenoid (SL2) to print a stamp about 6 mm from the trailing edge of the original.

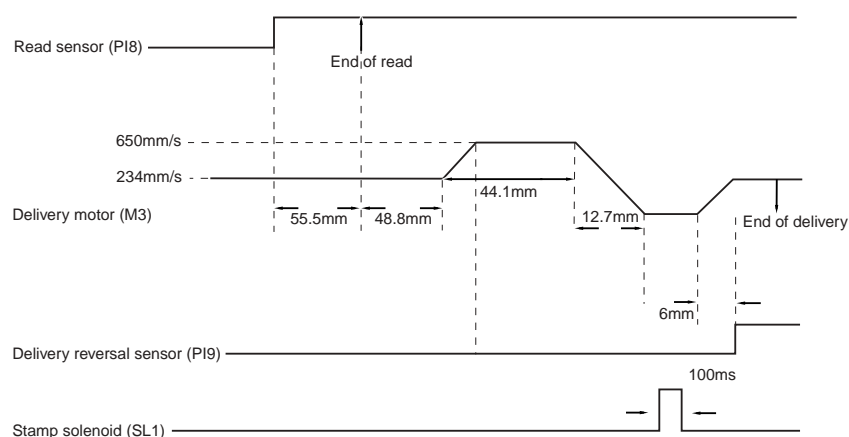

F-2-44

MEMO

A new stamp cartridge is good for about 7,000 stamps and you can find out how many times it has been used using the following service mode item. When you have fitted a stamp, be sure to execute the following so that the machine will recognize its presence: FEEDER>OPTION>STAMP-SW.

Chapter 3 Parts

Replacement Procedure

Contents

3.1 Removing from the Host Machine	3-1
3.1.1 Feeder	3-1
3.1.1.1 DADF-M1	3-1
3.2 External Covers	3-3
3.2.1 Front Cover.....	3-3
3.2.1.1 Removing the Front Cover	3-3
3.2.2 Rear Cover.....	3-3
3.2.2.1 Removing the Rear Cover	3-3
3.2.3 Lower Left Cover	3-3
3.2.3.1 Removing the Lower Left Cover.....	3-3
3.2.4 Feeder Cover	3-3
3.2.4.1 Removing the Front Cover	3-3
3.2.4.2 Removing the Feeder Cover	3-4
3.3 Drive System	3-5
3.3.1 Pickup Motor	3-5
3.3.1.1 Removing the Rear Cover	3-5
3.3.1.2 Removing the Pickup Motor	3-5
3.3.2 Feed Motor	3-5
3.3.2.1 Removing the Rear Cover	3-5
3.3.2.2 Removing the Harness Guide (right rear)	3-5
3.3.2.3 Removing the Cooling Fan.....	3-6
3.3.2.4 Removing the Feed motor	3-6
3.3.3 Delivery Reversal Motor	3-6
3.3.3.1 Removing the Rear Cover	3-6
3.3.3.2 Removing the Harness Guide (right rear)	3-7
3.3.3.3 Removing the Delivery Reversal Motor.....	3-7
3.3.4 Pressurization Motor	3-7
3.3.4.1 Removing the Front Cover	3-7
3.3.4.2 Removing the Harness Guide (front)	3-7
3.3.4.3 Removing the Locking Motor Drive Unit.....	3-8
3.3.4.4 Removing the Locking Motor	3-8
3.3.5 Drive Unit.....	3-8
3.3.5.1 Removing the Rear Cover	3-8
3.3.5.2 Removing the Harness Guide (right rear)	3-8
3.3.5.3 Removing the Delivery Reversal Motor Unit	3-9
3.3.5.4 Removing the Drive Unit	3-9
3.4 Document Feeding System.....	3-10
3.4.1 Pickup Roller Unit.....	3-10
3.4.1.1 Removing the Inside Cover	3-10
3.4.1.2 Removing the Pickup Roller Unit	3-10
3.4.2 Pickup Roller / Feed Roller	3-10
3.4.2.1 Removing the Inside Cover	3-10
3.4.2.2 Removing the Pickup Roller Unit	3-10
3.4.2.3 Removing the Pickup Roller and the Feeder Roller.....	3-10

3.4.3 Separation Plate/Separation Pad	3-11
3.4.3.1 Removing the Inside cover	3-11
3.4.3.2 Removing the Pickup Roller Unit.....	3-11
3.4.3.3 Removing the Separation Plate and the Separation Pad.....	3-11
3.4.3.4 Adjusting the Separation Pressure	3-12
3.4.4 No.1 Registration Roller Roll	3-12
3.4.4.1 Removing the Front Cover	3-12
3.4.4.2 Removing the Feeder cover	3-13
3.4.4.3 Removing the No. 1 Registration Roller Roll.....	3-13
3.4.5 No.1 Registration Roller	3-14
3.4.5.1 Removing the Front Cover	3-14
3.4.5.2 Removing the Rear Cover.....	3-14
3.4.5.3 Removing the Locking Motor Harness Guide.....	3-14
3.4.5.4 Removing the Locking Solenoid	3-14
3.4.5.5 Removing the Delivery Reversal Motor Unit.....	3-15
3.4.5.6 Removing the Pre-Registration Guide.....	3-15
3.4.5.7 Removing the No. 1 Registration Roller	3-15
3.4.6 No.2 Registration Roller Roll	3-16
3.4.6.1 Removing the Front Cover	3-16
3.4.6.2 Removing the Feeder Cover	3-16
3.4.6.3 Removing the No. 2 Registration Roller Roll.....	3-16
3.4.7 No.2 Registration Roller	3-17
3.4.7.1 Removing the Front Cover	3-17
3.4.7.2 Removing the Rear Cover.....	3-17
3.4.7.3 Removing the Cooling Fan	3-17
3.4.7.4 Removing the No. 2 Registration Roller	3-17
3.4.7.5 Removing the Feed Motor Unit	3-18
3.4.8 Delivery Reversing Roller (upper)	3-18
3.4.8.1 Removing the Front Cover	3-18
3.4.8.2 Removing the Rear Cover.....	3-19
3.4.8.3 Removing the Delivery Reversal Motor Unit.....	3-19
3.4.8.4 Removing the Drive Unit.....	3-19
3.4.8.5 Removing the Delivery Reversal Upper Roller.....	3-20
3.4.9 Read Roller 1	3-20
3.4.9.1 Removing the Front Cover	3-20
3.4.9.2 Removing the Rear Cover.....	3-20
3.4.9.3 Removing the Feeder cover	3-21
3.4.9.4 Removing the Locking Motor Harness Guide.....	3-21
3.4.9.5 Removing the Locking Motor Drive Unit	3-21
3.4.9.6 Removing the Cooling Fan	3-21
3.4.9.7 Removing the Feed motor.....	3-22
3.4.9.8 Removing the Platen Roll Downstream Unit	3-22
3.4.9.9 Removing the Platen Roller	3-23
3.4.9.10 Removing the Feed Guide	3-23
3.4.9.11 Removing the Bushing Fitted with a Plate	3-23
3.4.9.12 Removing the Read Roller 1.....	3-24
3.4.10 Platen Roller	3-25
3.4.10.1 Removing the Platen Roll Downstream Unit	3-25
3.4.10.2 Removing the Platen Roller.....	3-25

3.4.11 Platen Roller Roll Upstream.....	3-25
3.4.11.1 Removing the Lower Left Cover.....	3-25
3.4.11.2 Removing the Front Cover	3-26
3.4.11.3 Removing the Rear Cover	3-26
3.4.11.4 Removing the Feeder Cover.....	3-26
3.4.11.5 Removing the Locking Motor Drive Unit.....	3-26
3.4.11.6 Removing the Cooling Fan.....	3-27
3.4.11.7 Removing the Feed motor	3-27
3.4.11.8 Removing the Feed Guide.....	3-27
3.4.11.9 Removing the Bushing Fitted with a Plate.....	3-28
3.4.11.10 Removing the Platen Upstream Roll	3-29
3.4.12 Platen Roller Roll Downstream.....	3-29
3.4.12.1 Removing the Platen Downstream Roll Unit.....	3-29
3.4.12.2 Removing the Platen Downstream Roll	3-29
3.4.13 Delivery Reversing Roller (lower)	3-30
3.4.13.1 Removing the Inside Cover	3-30
3.4.13.2 Removing the Open/Close Guide.....	3-30
3.4.13.3 Removing the Delivery Reversal Lower Roller	3-30
3.4.14 Reversing Roller.....	3-30
3.4.14.1 Removing the Front Cover	3-30
3.4.14.2 Removing the Rear Cover	3-31
3.4.14.3 Removing the Locking Motor Harness Guide.....	3-31
3.4.14.4 Removing the Locking Motor Drive Unit.....	3-31
3.4.14.5 Removing the Cooling Fan.....	3-31
3.4.14.6 Removing the Feed Motor Unit.....	3-32
3.4.14.7 Removing the Reversing Roller	3-32
3.4.15 Reversion Roller Roll.....	3-33
3.4.15.1 Removing the Reversing Roll	3-33
3.4.16 Open/Close Guide Sheet	3-33
3.4.16.1 Removing the Open/Close Guide.....	3-33
3.4.16.2 Replacing the Open/Close Guide Sheet	3-33
3.4.17 Duct-Collection Sheet	3-33
3.4.17.1 Replacing the Dust-Colleting Sheet	3-33
3.5 Electrical System.....	3-35
3.5.1 Fan	3-35
3.5.1.1 Removing the Rear Cover	3-35
3.5.1.2 Removing the Cooling Fan.....	3-35
3.5.2 Document Width Volume	3-35
3.5.2.1 Removing the Inside Cover	3-35
3.5.2.2 Removing the Original Width Volume	3-35
3.5.2.3 Mounting the Original Width Volume	3-36
3.5.2.4 Adjusting the Side Guide Plate.....	3-36
3.5.3 Pressurization Solenoid	3-37
3.5.3.1 Removing the Front Cover	3-37
3.5.3.2 Removing the Locking Solenoid.....	3-37
3.5.4 ADF Driver PCB	3-37
3.5.4.1 Removing the Rear Cover	3-37
3.5.4.2 Removing the ADF Driver PCB.....	3-37
3.5.5 Separation Sensor	3-38

3.5.5.1 Removing the Inside Cover	3-38
3.5.5.2 Removing the Separation Read Sensor.....	3-38
3.5.6 Read Sensor	3-38
3.5.6.1 Removing the Front Cover	3-38
3.5.6.2 Removing the Feed Guide	3-39
3.5.6.3 Removing the Read Sensor.....	3-39
3.5.7 Delivery Reversal Sensor	3-39
3.5.7.1 Removing the Open/Close Guide	3-39
3.5.7.2 Removing the Delivery Guide	3-40
3.5.7.3 Removing the Delivery Reversal Sensor	3-40

3.1 Removing from the Host Machine

3.1.1 Feeder

3.1.1.1 DADF-M1

0003-7036

- 1) Turn off the control panel power switch [1].
- 2) Turn off the main power switch [2].
- 3) Disconnect the power cable (for the wall outlet) [3].

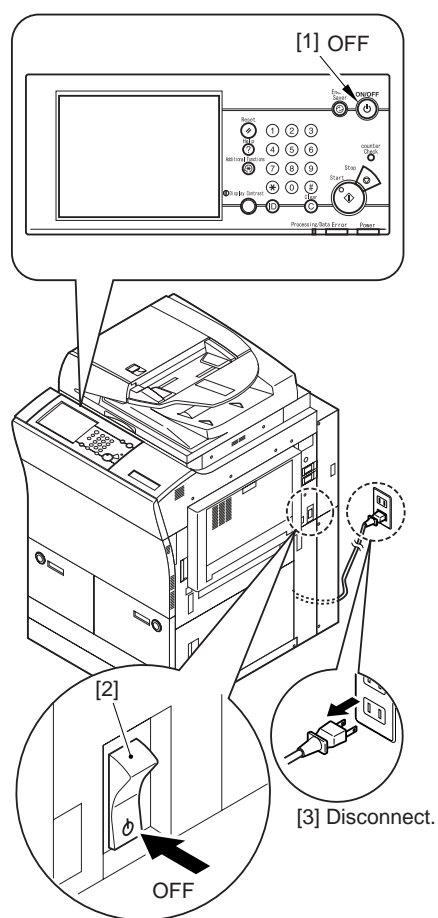

F-3-1

- 4) Disconnect the machine's communications cable [1] from its host machine.

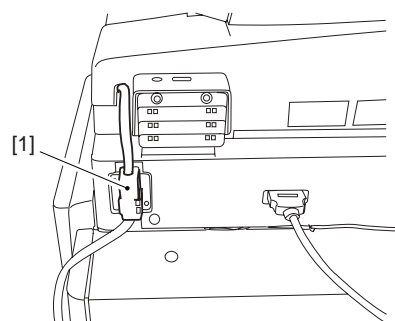

F-3-2

- 5) Bend up the edge of the rubber cover [1], and remove the 2 screws [2]; then, detach the angle guide plate [3].

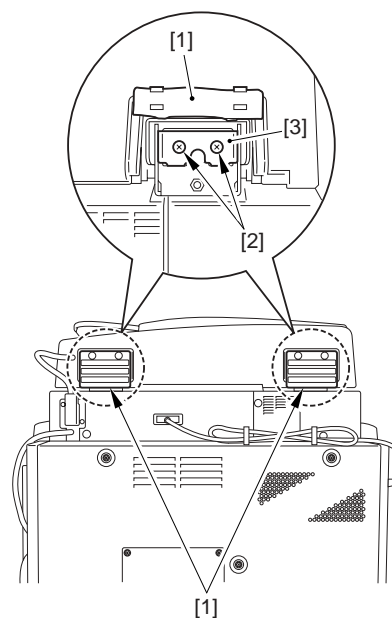

F-3-3

- 6) Remove the 3 knurled screws [1], and slide the machine toward the rear and lift it to detach.

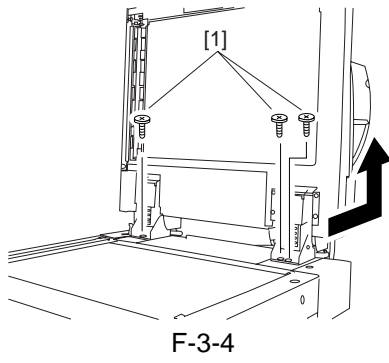

3.2 External Covers

3.2.1 Front Cover

3.2.1.1 Removing the Front

Cover [0003-7080](#)

- 1) Remove the 3 screws [1], and detach the front cover [2] by moving it in the direction of the arrow.

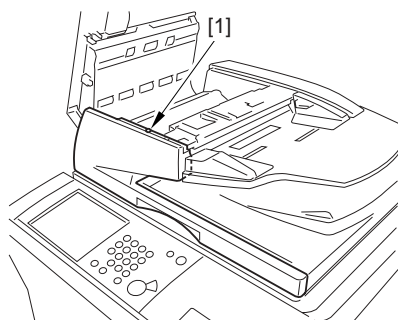

F-3-5

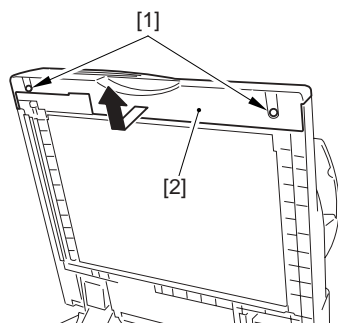

3.2.2 Rear Cover

3.2.2.1 Removing the Rear

Cover [0003-7110](#)

- 1) Open the feeder cover [1] and the original pickup tray [2]; then, remove the 4 screws [3], and detach the rear cover [4].

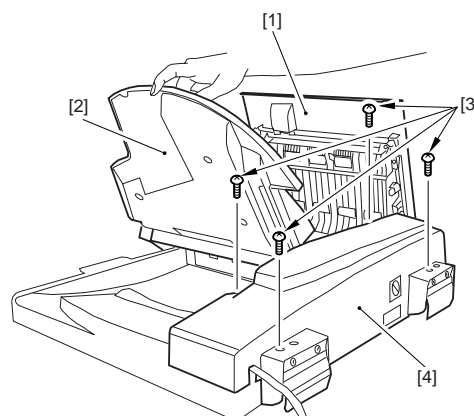

F-3-6

3.2.3 Lower Left Cover

3.2.3.1 Removing the Lower Left Cover

[0003-7120](#)

- 1) Remove the 2 screws [1], and detach the lower left cover [2].

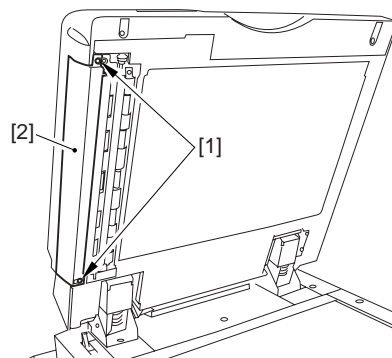

F-3-7

3.2.4 Feeder Cover

3.2.4.1 Removing the Front Cover

[0004-0321](#)

- 1) Remove the 3 screws [1], and detach the front cover [2] by moving it in the direction of the arrow.

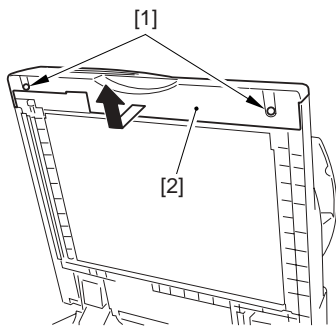
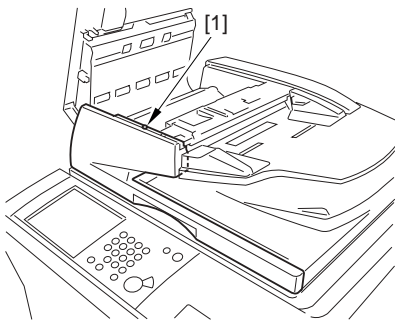

F-3-8

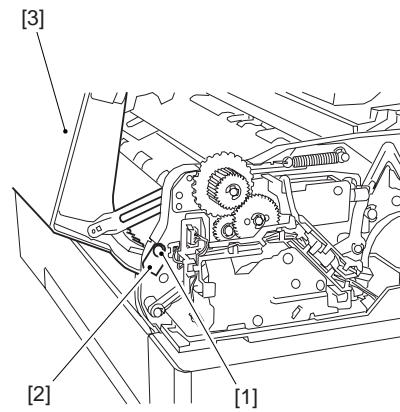

F-3-10

3.2.4.2 Removing the Feeder

Cover

0004-0320

1) Remove the E-ring [1].

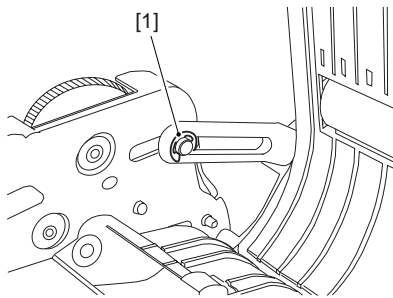

F-3-9

2) Remove the screw [1] and the positioning pin[2]; then, detach the feeder cover [3].

3.3 Drive System

3.3.1 Pickup Motor

3.3.1.1 Removing the Rear

Cover [0003-7141](#)

1) Open the feeder cover [1] and the original pickup tray [2]; then, remove the 4 screws [3], and detach the rear cover [4].

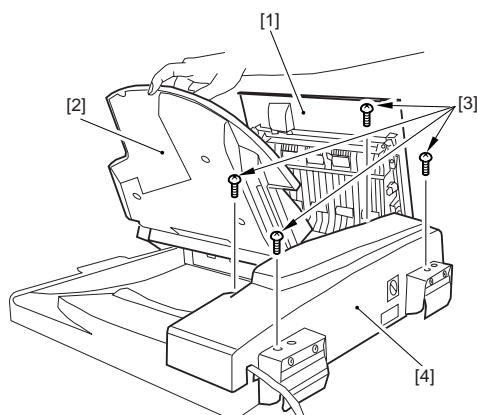

F-3-11

3.3.1.2 Removing the Pickup

Motor [0003-3079](#)

1) Disconnect the connector [1], and remove the 2 screws [2]; then, detach the pickup motor [3].

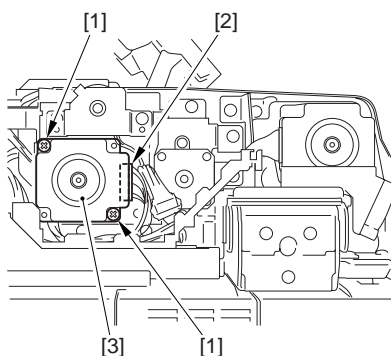

F-3-12

properly attached to the pulley.

3.3.2 Feed Motor

3.3.2.1 Removing the Rear

Cover [0003-7139](#)

1) Open the feeder cover [1] and the original pickup tray [2]; then, remove the 4 screws [3], and detach the rear cover [4].

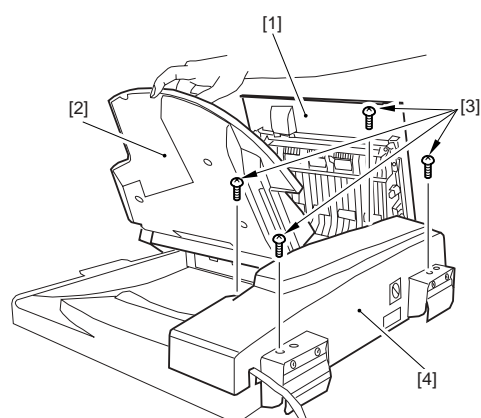

F-3-13

3.3.2.2 Removing the Harness

Guide (right rear) [0004-0816](#)

1) Remove the screw [1], and disconnect the 4 connectors [2]; then, free the harness from the harness guide [3].

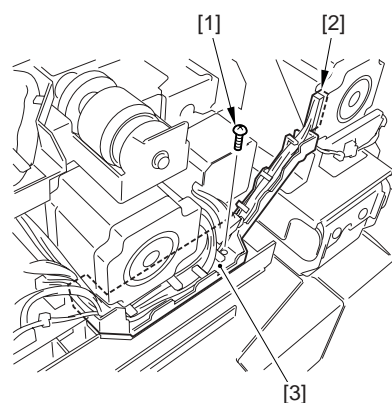

F-3-14

⚠ When mounting it, be sure that the timing belt is

3.3.2.3 Removing the Cooling

Fan 0003-7156

1) Remove the screw [1], and disconnect the connector [2]; then, detach the cooling fan [3].

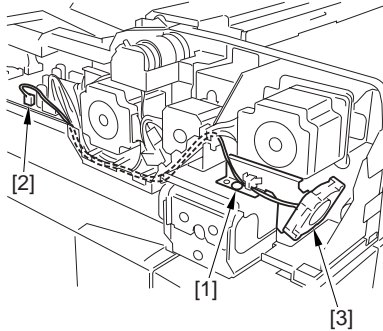

F-3-15

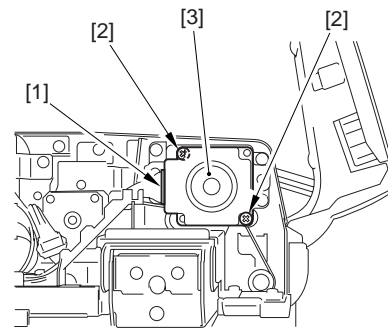

F-3-17

⚠ When mounting it, be sure that that timing belt [1] is properly attached to the pulley [2].

3.3.2.4 Removing the Feed

motor 0003-3083

1) Loosen the 2 screws [1], and move the feed motor [2] down; then, tighten the 2 screws [1] you have loosened.

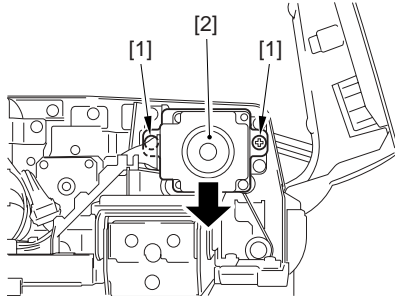

F-3-16

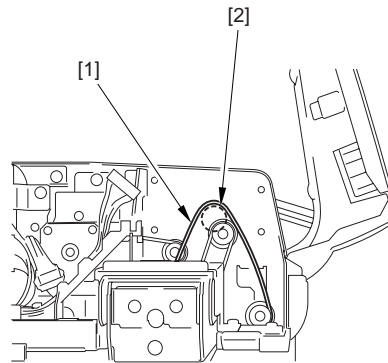

F-3-18

⚠ When mounting it, loosen the screws [1] to put it back to its initial position.

2) Disconnect the connector [1], and remove the 2 screws [2]; then, detach the feed roller [3].

3.3.3 Delivery Reversal Motor

3.3.3.1 Removing the Rear

Cover 0003-7168

1) Open the feeder cover [1] and the original pickup tray [2]; then, remove the 4 screws [3], and detach the rear cover [4].

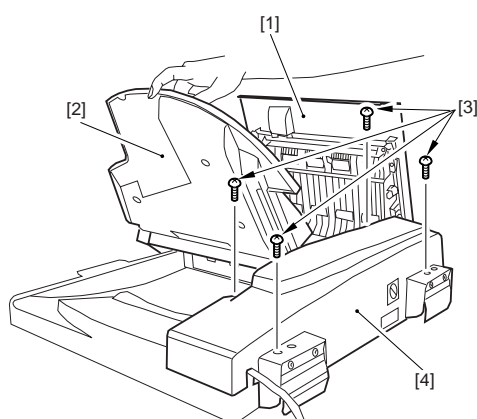

F-3-19

3.3.3.2 Removing the Harness

Guide (right rear)

0004-0817

- 1) Remove the screw [1], and disconnect the 4 connectors [2]; then, free the harness from the harness guide [3].

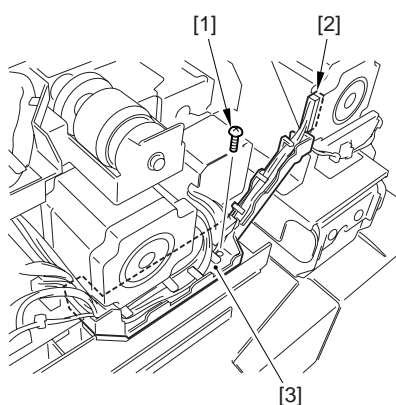

F-3-20

3.3.3.3 Removing the Delivery

Reversal Motor

0003-7164

- 1) Remove the 2 screws [1], and detach the delivery reversal motor [2].

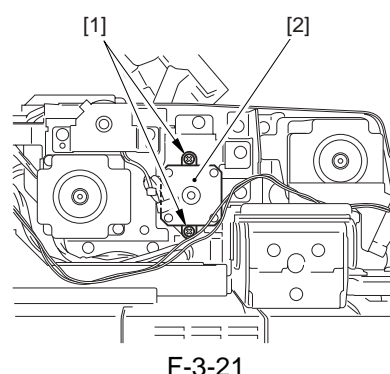

F-3-21

3.3.4 Pressurization Motor

3.3.4.1 Removing the Front

Cover

0003-7174

- 1) Remove the 3 screws [1], and detach the front cover [2] by moving it in the direction of the arrow.

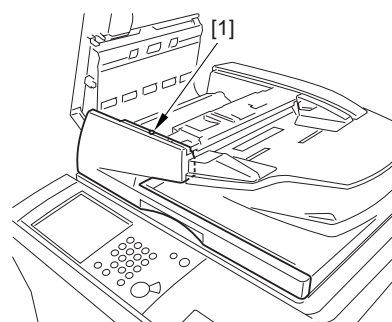

F-3-22

3.3.4.2 Removing the Harness

Guide (front)

0003-7176

- 1) Remove the screw [1], and disconnect the 3

connectors [2]; then, detach the harness guide [3].

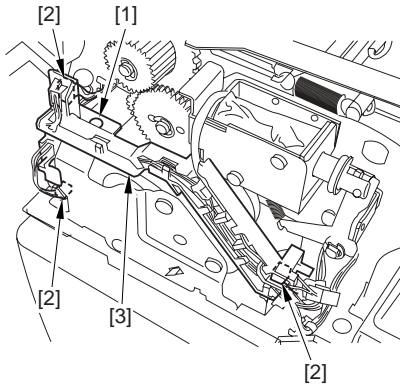

F-3-23

3.3.4.3 Removing the Locking Motor Drive Unit

0003-7178

1) Remove the 3 screws [1], and disconnect the connector [2]; then, detach the locking motor drive unit [3].

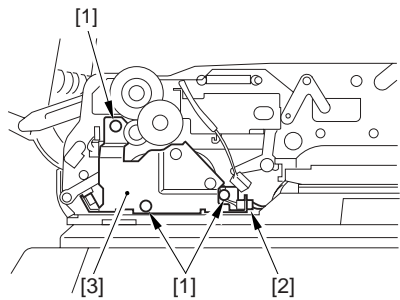

F-3-24

3.3.4.4 Removing the Locking Motor

0003-7180

1) Remove the 2 screws [1].

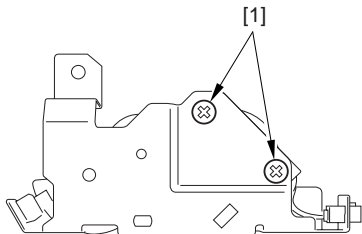

F-3-25

2) Remove the 2 screws [1], and disconnect the

connector [2]; then, detach the delivery reversal motor [3].

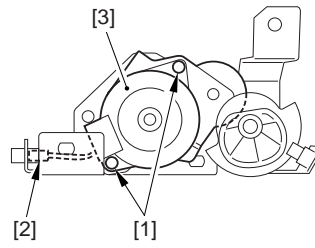

F-3-26

⚠ When mounting it, be sure that the motor harness is not trapped.

3.3.5 Drive Unit

3.3.5.1 Removing the Rear

Cover

0004-0691

1) Open the feeder cover [1] and the original pickup tray [2]; then, remove the 4 screws [3], and detach the rear cover [4].

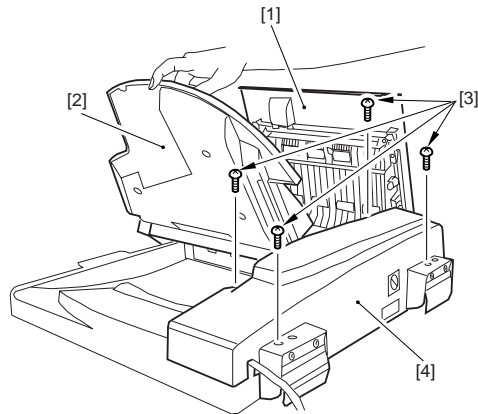

F-3-27

3.3.5.2 Removing the Harness

Guide (right rear)

0004-0818

1) Remove the screw [1], and disconnect the 4 connectors [2]; then, free the harness from the harness

guide [3].

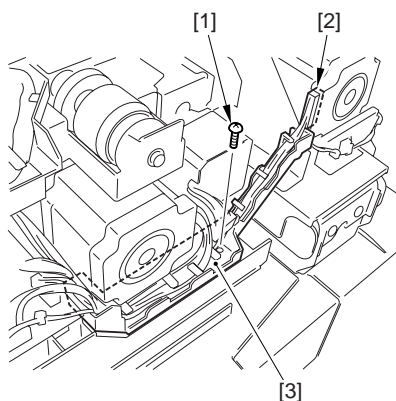

F-3-28

3.3.5.3 Removing the Delivery

Reversal Motor Unit

0004-0693

1) Remove the 2 screws [1], and detach the delivery reversal motor unit [2].

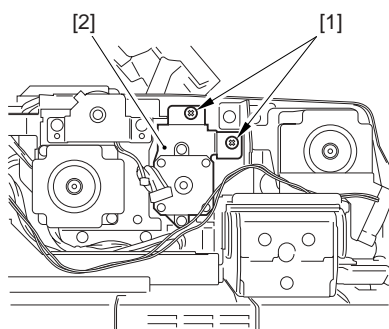

F-3-29

3.3.5.4 Removing the Drive

Unit

0004-0689

1) Remove the 4 screws [1], and detach the drive unit [2].

⚠ Be sure to free the harness from the wire saddle [3]. When mounting it, be sure to route the harness through the wire saddle [3].

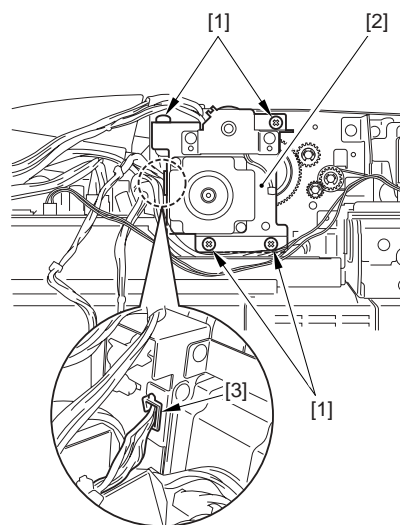

F-3-30

⚠ After mounting it, check to make sure that the arm [1] of the pickup clutch is above the bin [2].

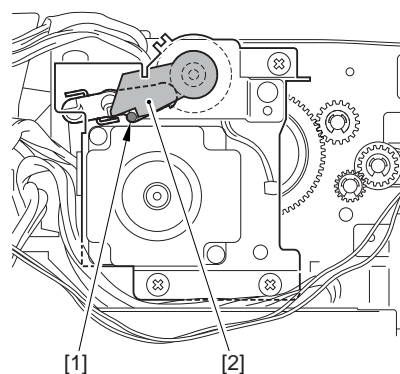

F-3-31

3.4 Document Feeding System

3.4.1 Pickup Roller Unit

3.4.1.1 Removing the Inside

Cover [0003-3089](#)

1) Open the feeder cover, and remove the 2 screws [1]; then, detach the inside cover [2].

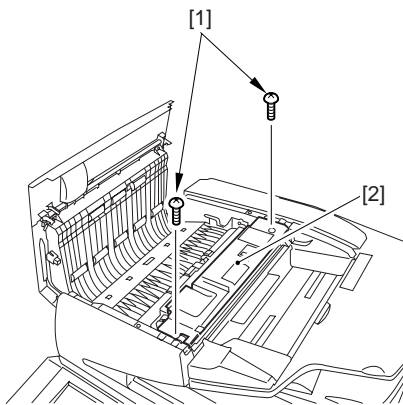

F-3-32

3.4.1.2 Removing the Pickup

Roller Unit [0003-3095](#)

1) Remove the 2 resin E-rings [1] and the 2 bushings [2]; then, detach the pickup roller unit [3].

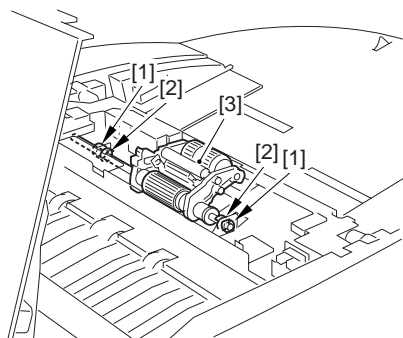

F-3-33

3.4.2 Pickup Roller / Feed Roller

3.4.2.1 Removing the Inside

Cover [0004-6029](#)

1) Open the feeder cover, and remove the 2 screws [1]; then, detach the inside cover [2].

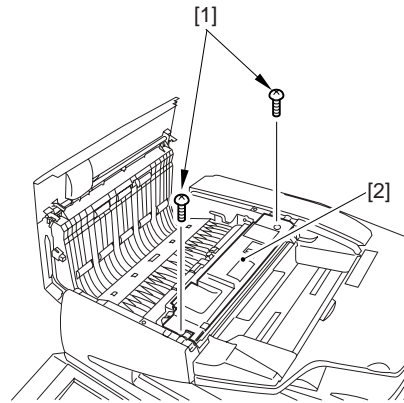

F-3-34

3.4.2.2 Removing the Pickup

Roller Unit [0004-6030](#)

1) Remove the 2 resin E-rings [1] and the 2 bushings [2]; then, detach the pickup roller unit [3].

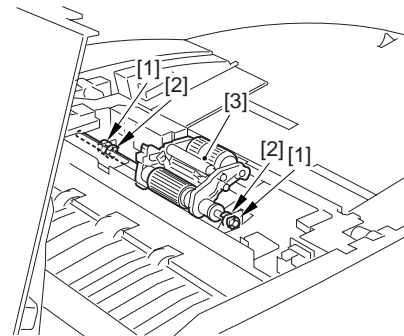

F-3-35

3.4.2.3 Removing the Pickup

Roller and the Feeder Roller [0004-6028](#)

1) Remove the 3 resin E-rings [1], and detach the pickup roller support base [2].

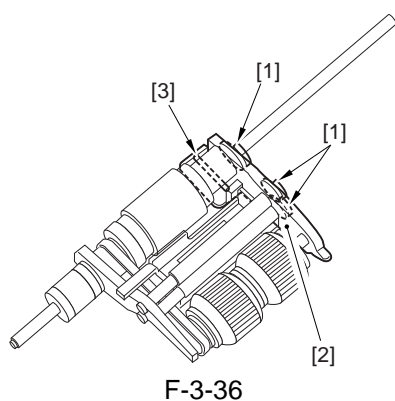

⚠ When detaching it, be sure not to lose the pin [3], as it will come off upon detachment.

2) Remove the feeder roller [4].

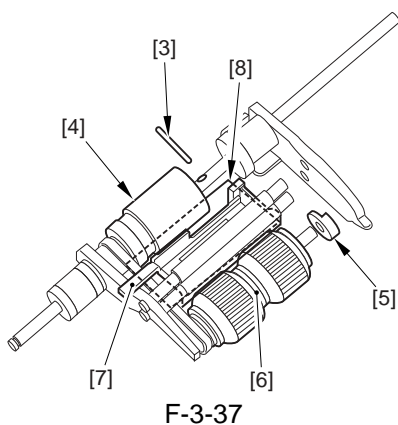

3) Remove the resin E-ring [5], and detach the pickup roller [6].

⚠ Pay attention to the orientation of the pickup roller and the feed roller.

Moreover, be sure that the separation front guide [7] is mounted so that the wider side of the sheet [8] is toward the pickup roller side.

3.4.3 Separation Plate/Separation Pad

3.4.3.1 Removing the Inside

cover [0003-3488](#)

1) Open the feeder cover, and remove the 2 screws [1]; then, detach the inside cover [2].

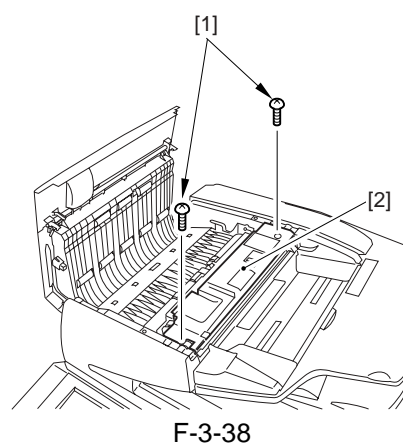

3.4.3.2 Removing the Pickup

Roller Unit [0003-3489](#)

1) Remove the 2 resin E-rings [1] and the 2 bushings [2]; then, detach the pickup roller unit [3].

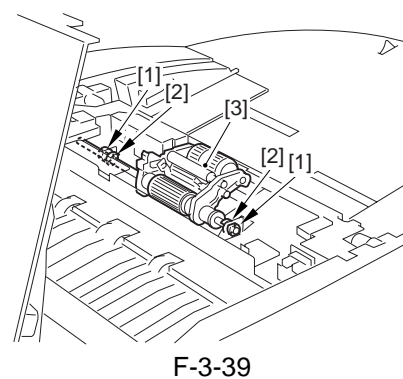

3.4.3.3 Removing the Separation Plate and the Separation Pad

[0003-3486](#)

1) Remove the 2 screws [1], and detach the separation plate [2] and the separation pad [3].

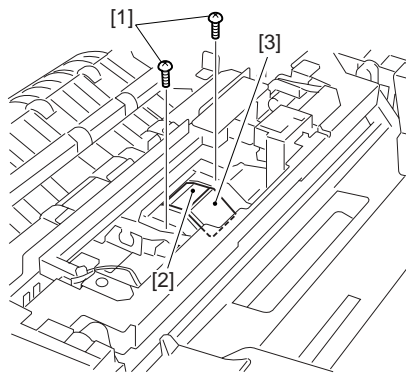

F-3-40

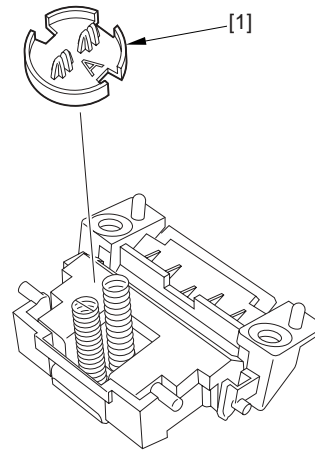

F-3-41

3.4.3.4 Adjusting the Separation Pressure 0003-3495

Memo

Make the following adjustments if such feeding faults as multiple feeding occur.

T-3-1

Pressure adjusting roll	Separation pressure
Side A	low
Side B	high

- 1) Turn over the pressure adjusting roll [1] (found fitted to the spring), and fit it in place (turn it over from side A to side B).

⚠ When fitting the spring in place, be sure it is oriented correctly, i.e., the spring [1] with a bend being upstream in relation to feed direction.

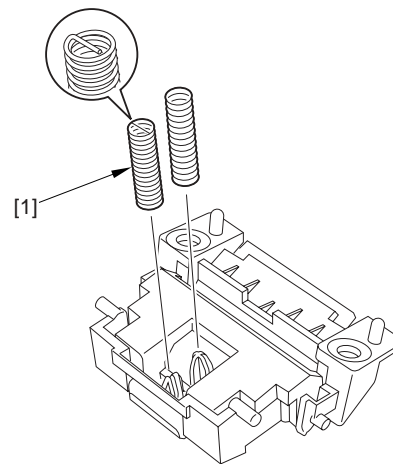

F-3-42

3.4.4 No.1 Registration Roller Roll

3.4.4.1 Removing the Front Cover 0003-7215

- 1) Remove the 3 screws [1], and detach the front cover [2] by moving it in the direction of the arrow.

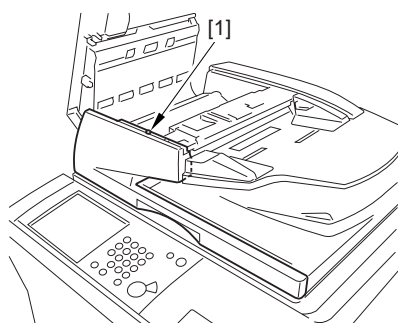

F-3-43

3.4.4.2 Removing the Feeder cover

0004-6031

1) Remove the E-ring [1].

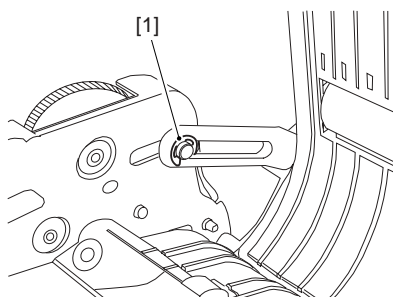

F-3-44

2) Remove the screw [1] and the positioning pin [2]; then, detach the feeder cover [3].

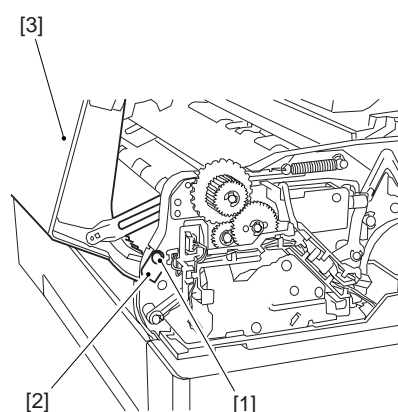

F-3-45

3.4.4.3 Removing the No. 1 Registration Roller Roll

0003-7220

1) Remove the 4 screws [1], and detach the cover.

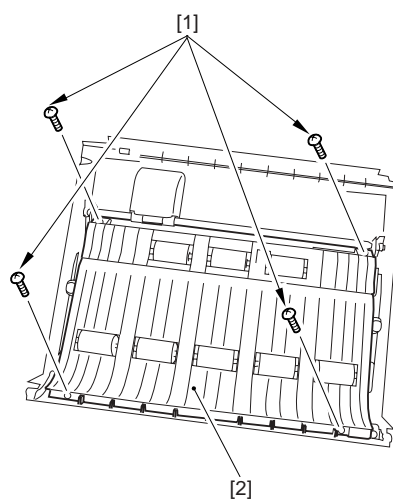

F-3-46

2) Remove the screw [1], and detach the support plate; then, detach the No. 1 registration roller roll [2].

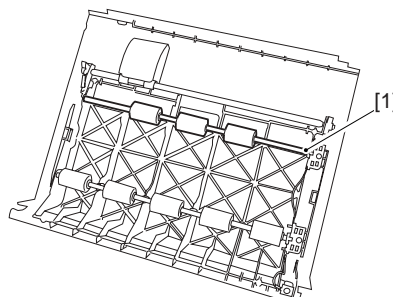

F-3-47

3.4.5 No.1 Registration Roller

3.4.5.1 Removing the Front

Cover

0003-7208

- 1) Remove the 3 screws [1], and detach the front cover [2] by moving it in the direction of the arrow.

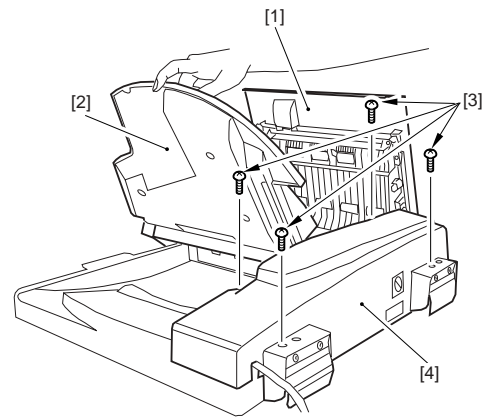
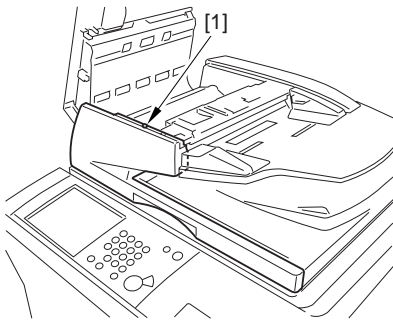

F-3-49

3.4.5.3 Removing the Locking

Motor Harness Guide

0003-8036

- 1) Remove the screw [1], and disconnect the 3 connectors [2]; then, detach the harness guide [3].

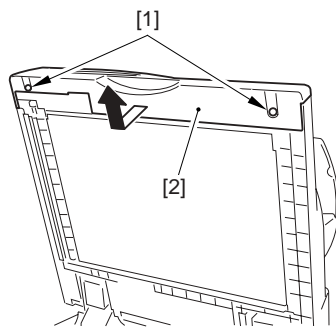

F-3-48

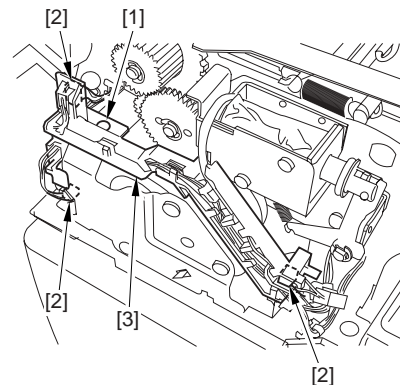

F-3-50

3.4.5.2 Removing the Rear

Cover

0003-8035

- 1) Open the feeder cover [1] and the original pickup tray [2]; then, remove the 4 screws [3], and detach the rear cover [4].

3.4.5.4 Removing the Locking

Solenoid

0003-8038

- 1) Remove the 2 screws [1] and the spring [2]; then, detach the locking solenoid [3].

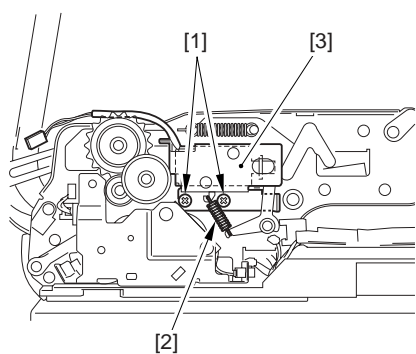

F-3-51

3.4.5.5 Removing the Delivery Reversal Motor Unit

0004-0386

- 1) Remove the 2 screws [1], and detach the delivery reversal motor unit [2].

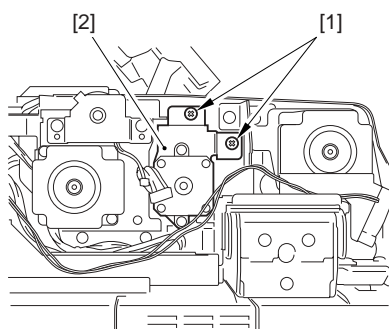

F-3-52

3.4.5.6 Removing the Pre-Registration Guide

0004-0432

- 1) Remove the 2 screws [1], and detach the pre-registration guide [2].

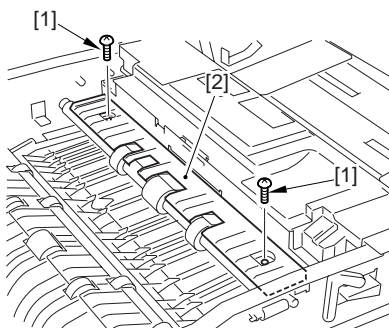

F-3-53

3.4.5.7 Removing the No. 1 Registration Roller

0003-8040

- 1) Remove the E-ring [1] and the bushing [2].

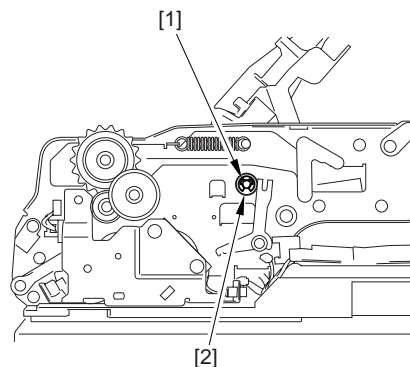

F-3-54

- 2) Remove the E-ring [1], gear [2], and bushing [3].

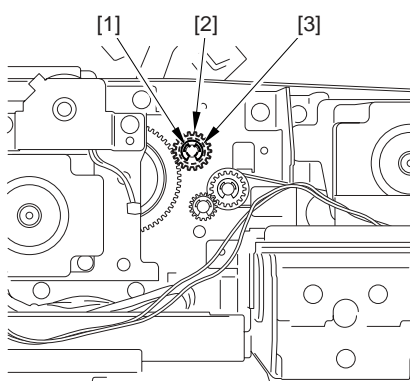

F-3-55

- 3) Remove the No. 1 registration roller [1].

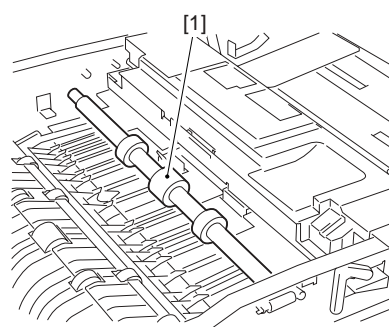

F-3-56

3.4.6 No.2 Registration Roller Roll

3.4.6.1 Removing the Front Cover

Cover 0003-8042

- 1) Remove the 3 screws [1], and detach the front cover [2] by moving it in the direction of the arrow.

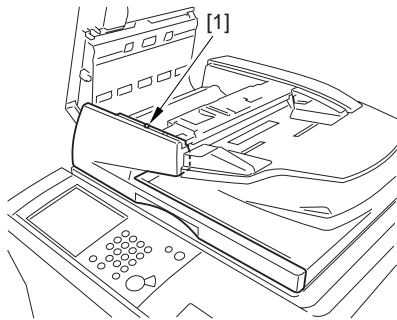

F-3-57

3.4.6.2 Removing the Feeder Cover

Cover 0004-6032

- 1) Remove the E-ring [1].

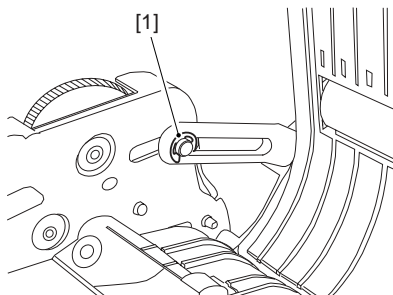

F-3-58

- 2) Remove the screw [1] and the positioning pin [2];

then, detach the feeder cover [3].

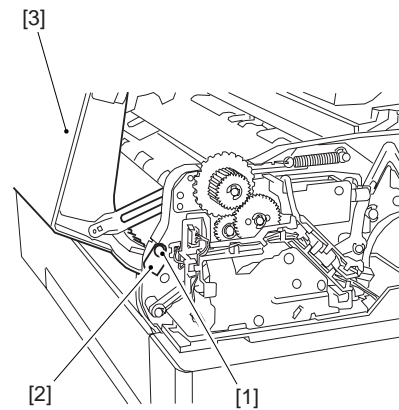

F-3-59

3.4.6.3 Removing the No. 2 Registration Roller Roll

0003-8043

- 1) Remove the 4 screws [1], and detach the cover [2].

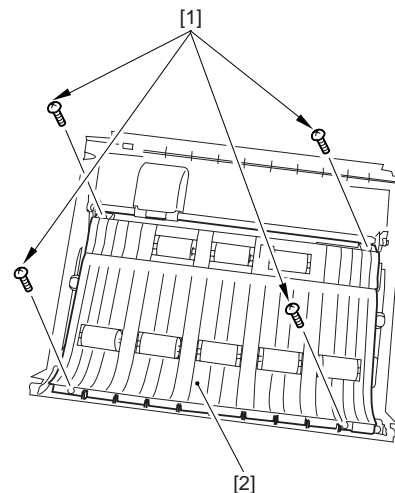

F-3-60

- 2) Remove the screw [1], and detach the support plate; then, detach the No. 2 registration upper roller roll [2].

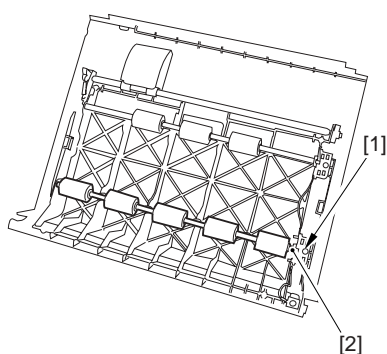

F-3-61

3.4.7 No.2 Registration Roller

3.4.7.1 Removing the Front

Cover [0003-8044](#)

- 1) Remove the 3 screws [1], and detach the front cover [2] by moving it in the direction of the arrow.

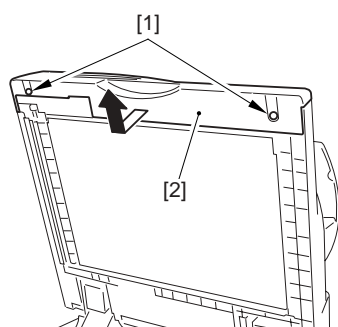
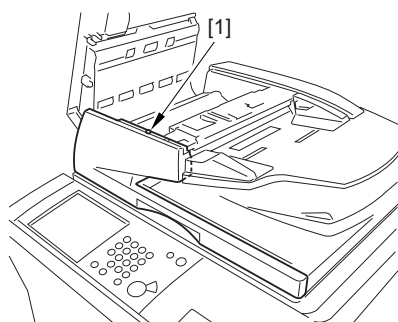

F-3-62

3.4.7.2 Removing the Rear

Cover [0003-8045](#)

- 1) Open the feeder cover [1] and the original pickup

tray [2]; then, remove the 4 screws [3], and detach the rear cover [4].

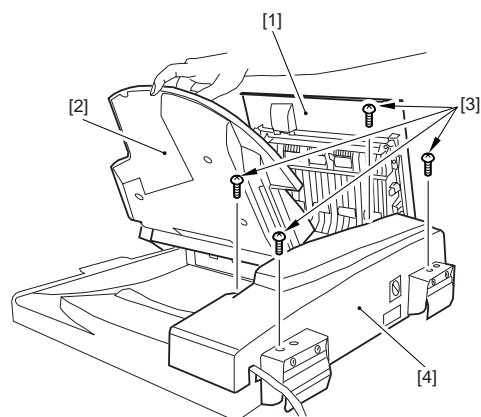

F-3-63

3.4.7.3 Removing the Cooling

Fan [0003-8046](#)

- 1) Remove the screw [1], and disconnect the connector [2]; then, detach the cooling fan [3].

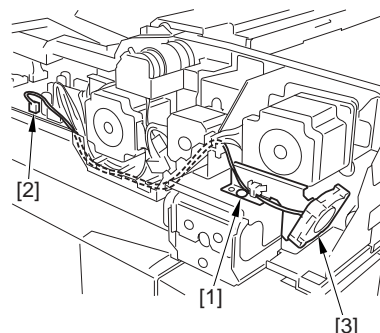

F-3-64

3.4.7.4 Removing the No. 2

Registration Roller [0003-8047](#)

- 1) Remove the 3 E-rings [1], 3 gears [2], and 2 bushings [3]; then, detach the No. 1 registration roller [4].

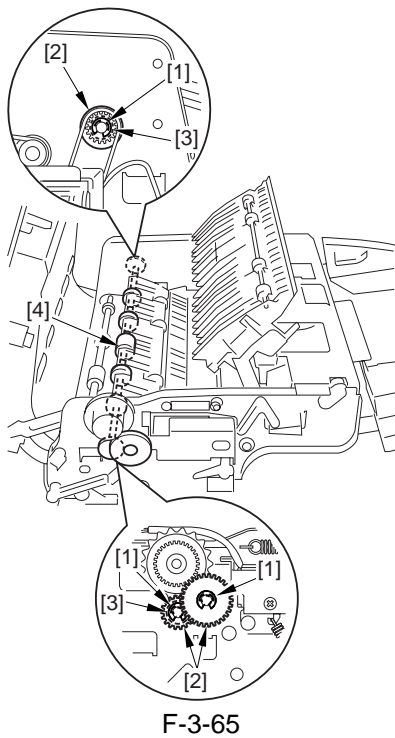

F-3-65

3.4.7.5 Removing the Feed

Motor Unit

0005-0409

1) Loosen the 2 screws [1], and move down the feed motor [2]; then, tighten the 2 screws you have loosened [1].

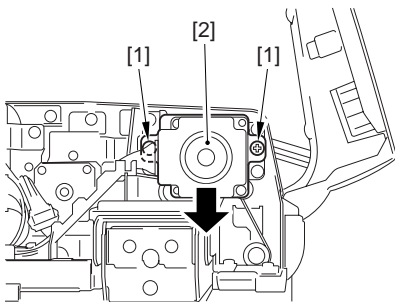

F-3-66

⚠ When mounting it, be sure to loosen the screws [1] and move the feed motor [2] back into its initial position.

2) Remove the 4 screws [1], and disconnect the

connector [2]; then, detach the feed motor unit [3].

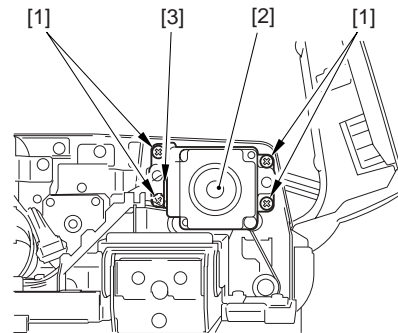

F-3-67

⚠ When mounting it, be sure that the timing belt [1] is properly attached to the pulley [2].

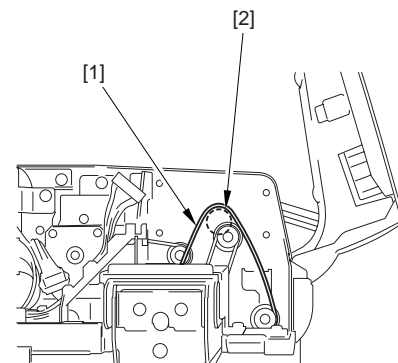

F-3-68

3.4.8 Delivery Reversing Roller (upper)

3.4.8.1 Removing the Front

Cover

0003-7081

1) Remove the 3 screws [1], and detach the front cover [2] by moving it in the direction of the arrow.

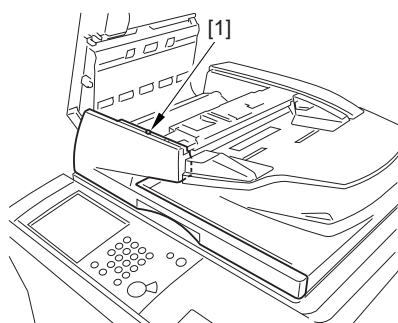

F-3-69

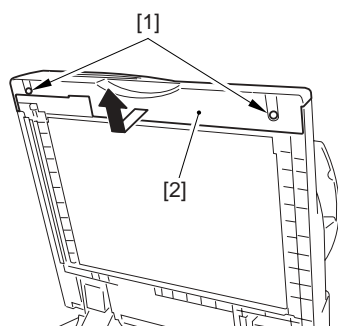

3.4.8.2 Removing the Rear

Cover

0003-7138

1) Open the feeder cover [1] and the original pickup tray [2]; then, remove the 4 screws [3], and detach the rear cover [4].

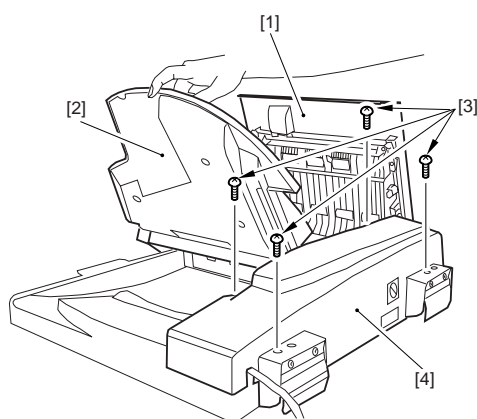

F-3-70

3.4.8.3 Removing the Delivery

Reversal Motor Unit

0004-0464

1) Remove the 2 screws [1], and detach the delivery

reversal motor unit [2].

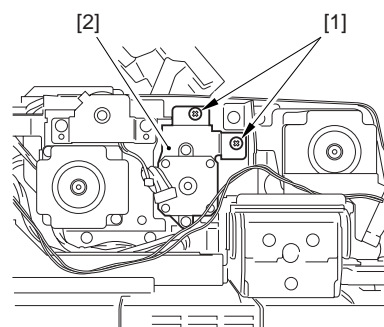

F-3-71

3.4.8.4 Removing the Drive

Unit

0004-0695

1) Remove the 4 screws [1], and detach the drive unit [2].

⚠ Be sure to free the harness from the wire saddle [3]. When mounting it, be sure to route the harness through the wire saddle [3].

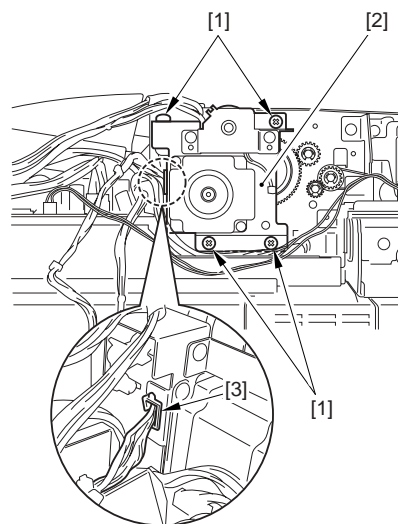

F-3-72

⚠ After mounting it, check to make sure that the arm [1] of the pickup clutch is above the bin [2].

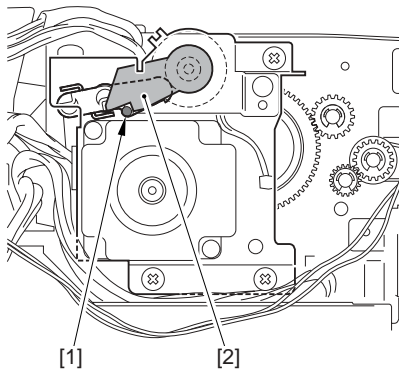

F-3-73

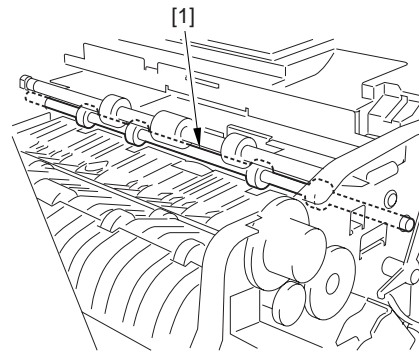

F-3-76

3.4.8.5 Removing the Delivery

Reversal Upper Roller

0003-5845

- 1) Remove the E-ring [1] and the bushing [2].

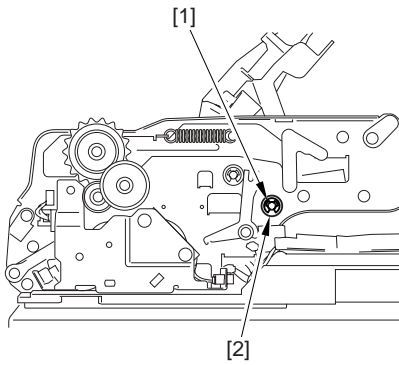

F-3-74

- 2) Remove the E-ring [1], gear [2], and bushing [3].

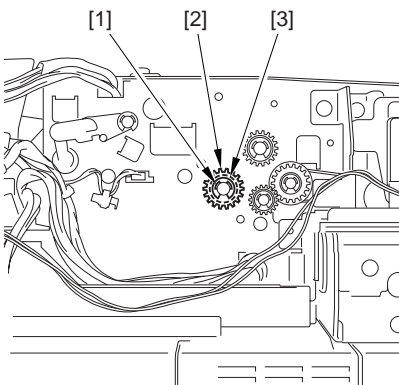

F-3-75

- 3) Remove the delivery reversal upper roller [1].

3.4.9 Read Roller 1

3.4.9.1 Removing the Front

Cover

0003-8048

- 1) Remove the 3 screws [1], and detach the front cover [2] by moving it in the direction of the arrow.

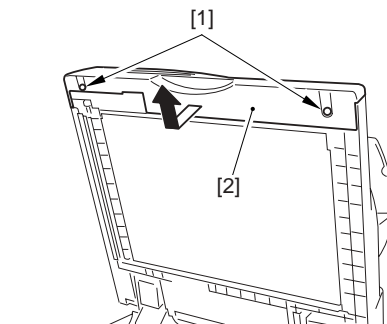
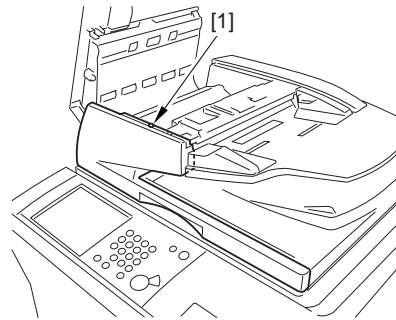

F-3-77

3.4.9.2 Removing the Rear

Cover

0003-8050

- 1) Open the feeder cover [1] and the original pickup

tray [2]; then, remove the 4 screws [3], and detach the rear cover [4].

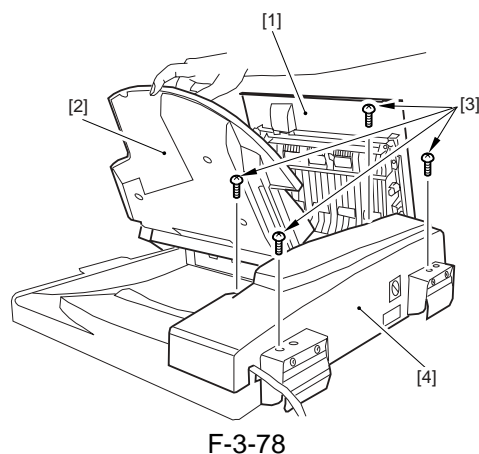

3.4.9.3 Removing the Feeder

cover

0004-0710

1) Remove the E-ring [1].

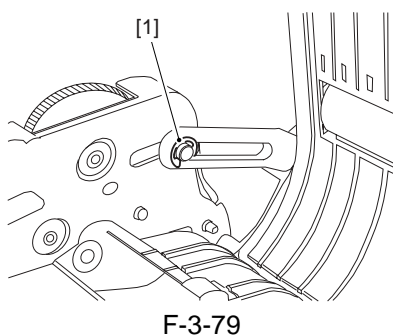

2) Remove the screw [1] and the positioning pin [2]; then, detach the feeder cover [3].

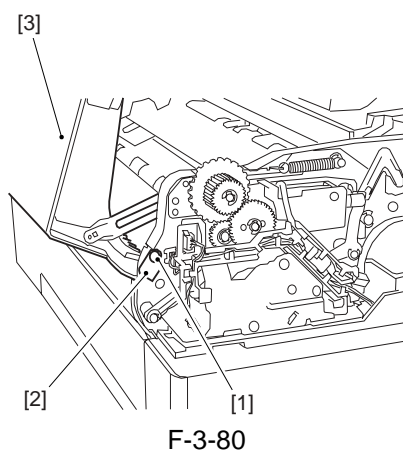

3.4.9.4 Removing the Locking

Motor Harness Guide

0003-8052

1) Remove the screw [1], and disconnect the 3 connectors [2]; then, detach the harness guide [3].

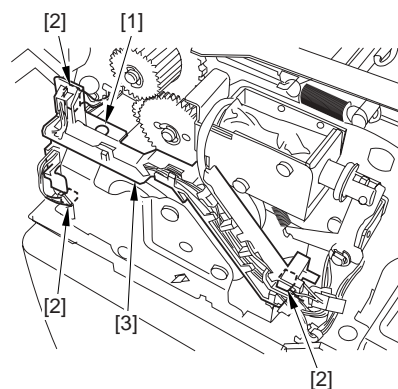

3.4.9.5 Removing the Locking

Motor Drive Unit

0003-8053

1) Remove the 3 screws [1], and disconnect the connector [2]; then, detach the locking motor drive unit [3].

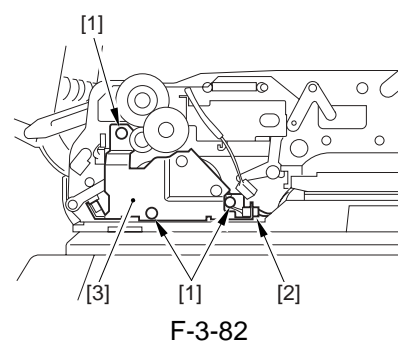

3.4.9.6 Removing the Cooling

Fan

0003-8068

1) Remove the screw [1], and disconnect the connector [2]; then, detach the cooling fan [3].

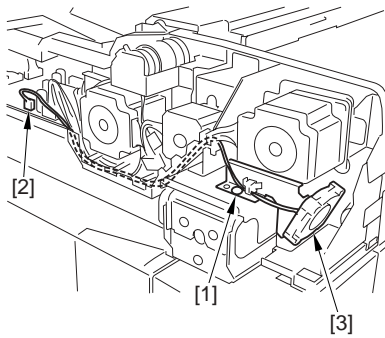

F-3-83

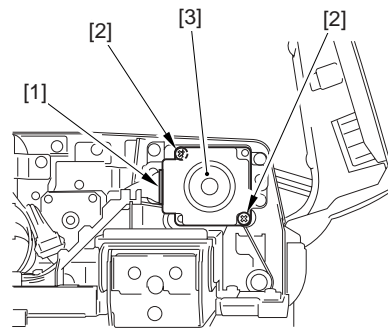

F-3-85

3.4.9.7 Removing the Feed

motor

0003-8069

1) Loosen the 2 screws [1], and move the feed motor [2] down; then, tighten the 2 screws [1] you have loosened.

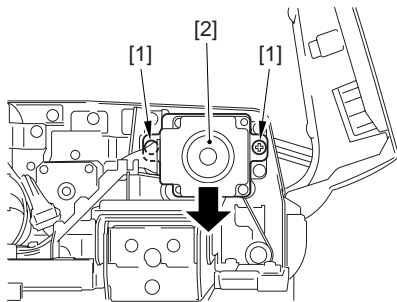

F-3-84

⚠ When mounting it, be sure that that timing belt [1] is properly attached to the pulley [2].

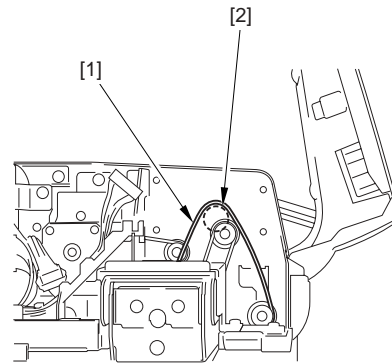

F-3-86

⚠ When mounting it, loosen the screws [1] to put it back to its initial position.

2) Disconnect the connector [1], and remove the 2 screws [2]; then, detach the feed roller [3].

3.4.9.8 Removing the Platen

Roll Downstream Unit

0004-0446

1) Remove the screw [1], and detach the platen downstream roll unit [2].

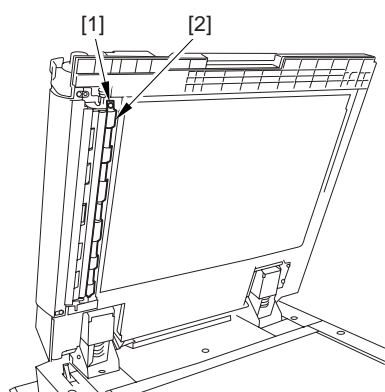

F-3-87

3.4.9.9 Removing the Platen

Roller

0003-8085

1) Detach the belt [1], and remove the 2 resin E-rings [2] and the 2 bushings [3]: then, detach the platen roller [4].

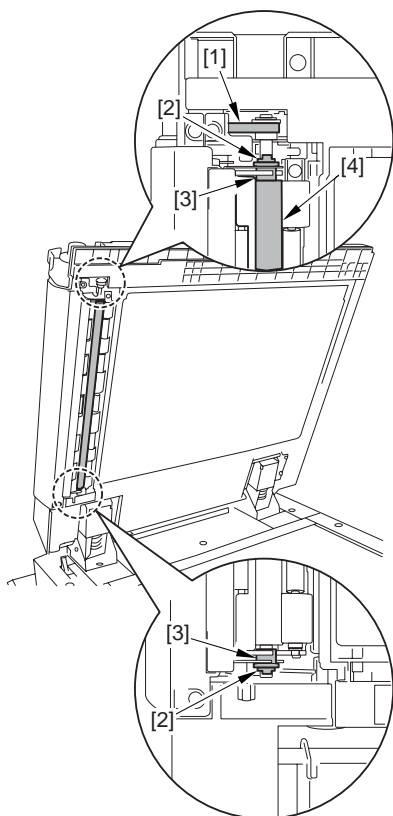

F-3-88

3.4.9.10 Removing the Feed

Guide

0003-8086

1) Open the open/close guide [1]; then, remove the 2 screws [2], and disconnect the connector [3] to detach the feed guide [4].

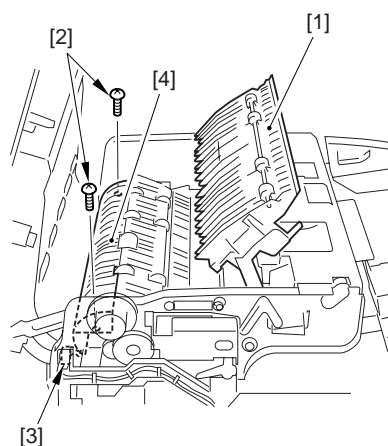

F-3-89

3.4.9.11 Removing the Bushing

Fitted with a Plate

0004-5584

1) Remove the E-ring [1], gear [2], and bushing [3].

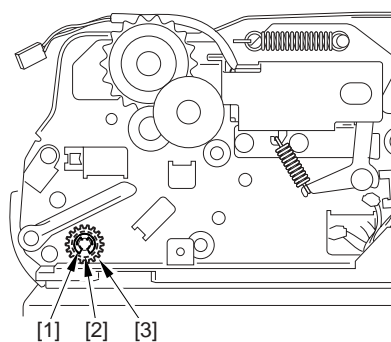

F-3-90

2) Remove the ring [1], gear [2], and busing [3].

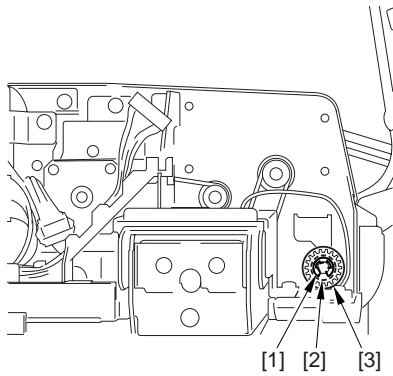

F-3-91

3) Release the pressure spring [1].

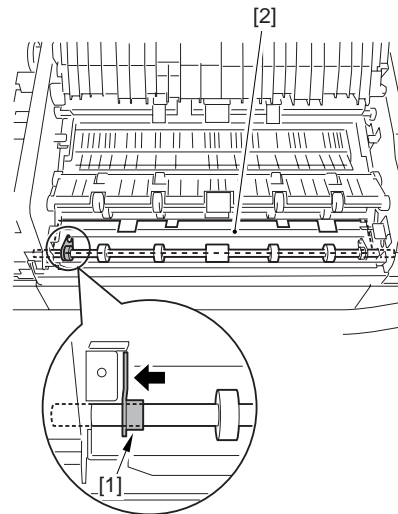

F-3-94

3.4.9.12 Removing the Read

Roller 1

0004-5585

1) As shown, shift up the ADF, and move the reader roller 1 unit [1] as low as it moves.

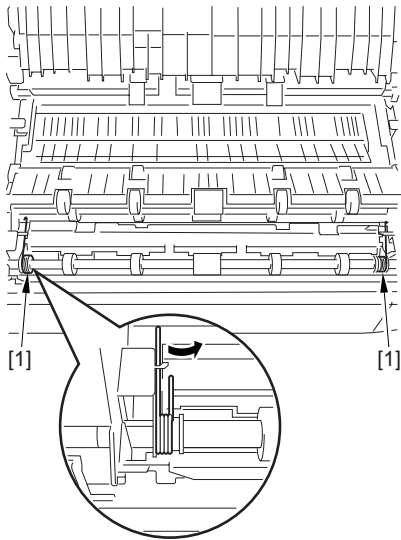

F-3-92

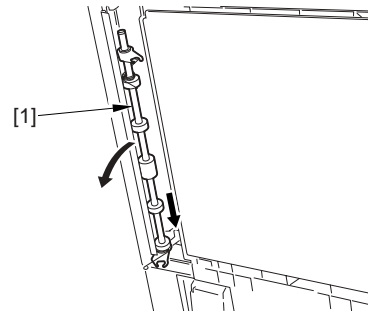

F-3-95

4) Remove the 2 E-rings [1].

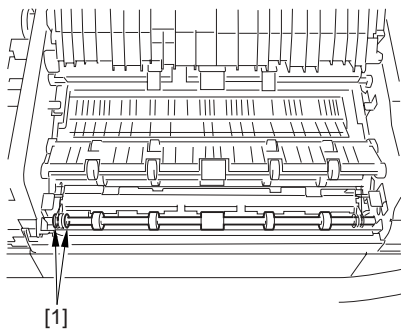

F-3-93

2) Remove the 2 E-rings [1], 2 pressure springs [2], and 2 bushings [3] fitted with a plate; then, detach the read roller [4].

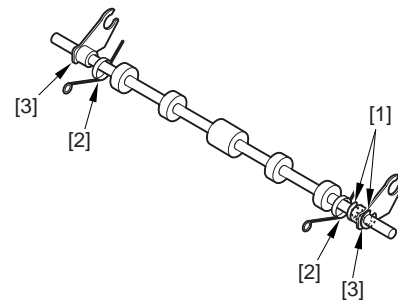

F-3-96

5) Slide the bushing [1] fitted with a plate toward the rear, and detach the platen guide [2].

3.4.10 Platen Roller

3.4.10.1 Removing the Platen

Roll Downstream Unit 0004-0444

- 1) Remove the screw [1], and detach the platen downstream roll unit [2].

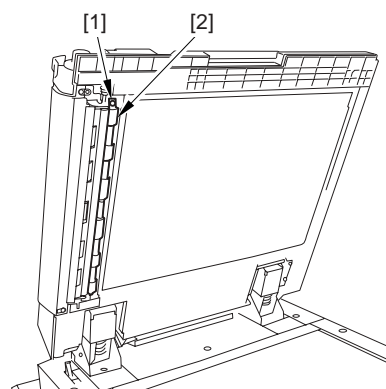

F-3-97

3.4.10.2 Removing the Platen

Roller 0003-5716

- 1) Detach the belt [1], and remove the 2 resin E-rings [2] and the 2 bushings [3]: then, detach the platen roller [4].

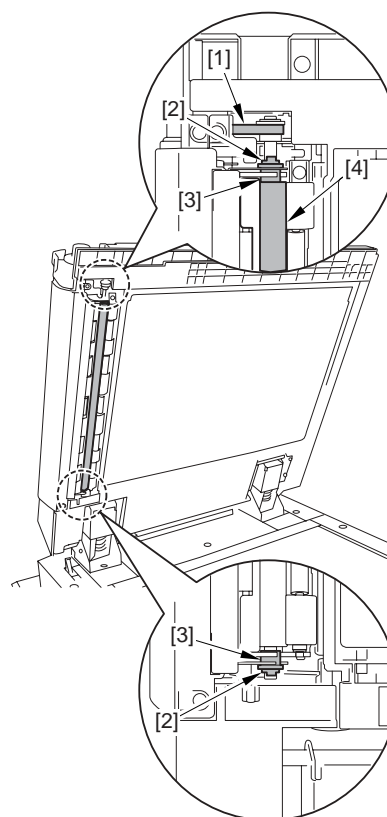

F-3-98

3.4.11 Platen Roller Roll Upstream

3.4.11.1 Removing the Lower

Left Cover 0004-1939

- 1) Remove the 2 screws [1], and detach the lower left cover [2].

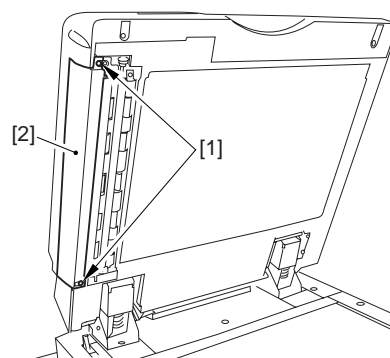

F-3-99

3.4.11.2 Removing the Front

Cover

0004-1940

1) Remove the 3 screws [1], and detach the front cover [2] by moving it in the direction of the arrow.

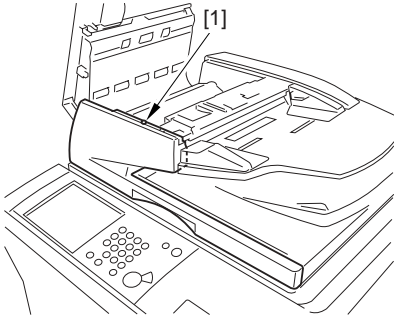

F-3-100

3.4.11.3 Removing the Rear

Cover

0004-1941

1) Open the feeder cover [1] and the original pickup tray [2]; then, remove the 4 screws [3], and detach the rear cover [4].

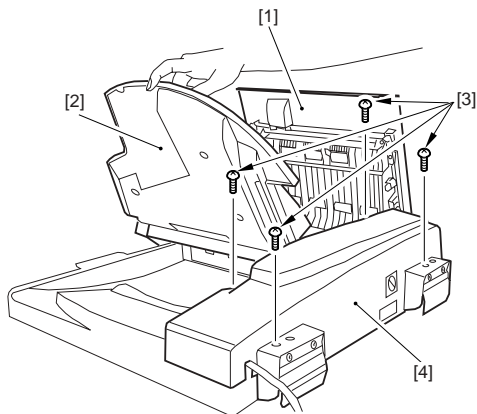

F-3-101

3.4.11.4 Removing the Feeder

Cover

0004-1942

1) Remove the E-ring [1].

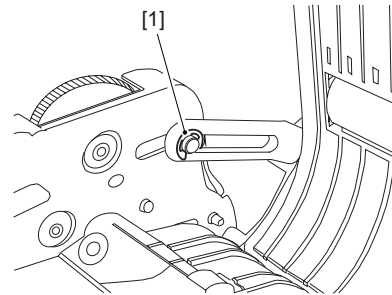

F-3-102

2) Remove the screw [1] and the positioning pin [2]; then, detach the feeder cover [3].

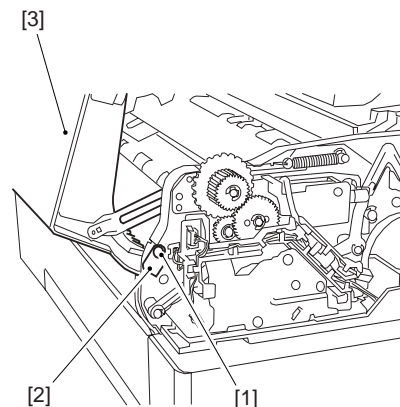

F-3-103

3.4.11.5 Removing the Locking

Motor Drive Unit

0004-1943

1) Remove the 3 screws [1], and disconnect the connector [2]; then, detach the locking motor drive unit [3].

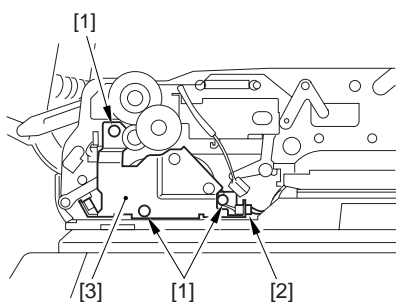

F-3-104

3.4.11.6 Removing the Cooling

Fan

0004-1944

1) Remove the screw [1], and disconnect the connector [2]; then, detach the cooling fan [3].

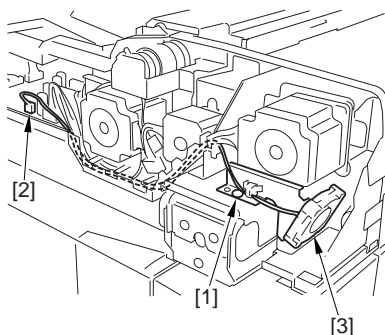

F-3-105

3.4.11.7 Removing the Feed

motor

0004-1945

1) Loosen the 2 screws [1], and move the feed motor [2] down; then, tighten the 2 screws [1] you have loosened.

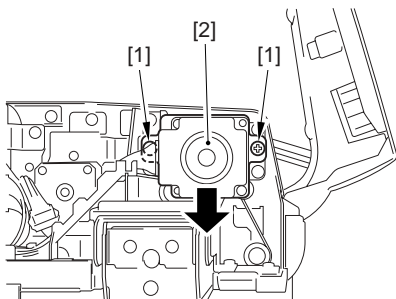

F-3-106

⚠ When mounting it, loosen the screws [1] to put it back to its initial position.

2) Disconnect the connector [1], and remove the 2 screws [2]; then, detach the feed roller [3].

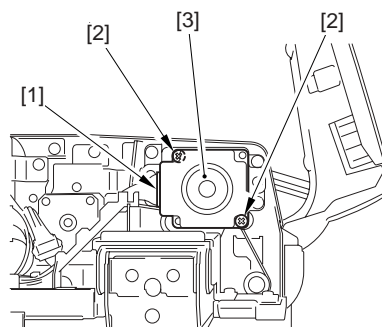

F-3-107

⚠ When mounting it, be sure that that timing belt [1] is properly attached to the pulley [2].

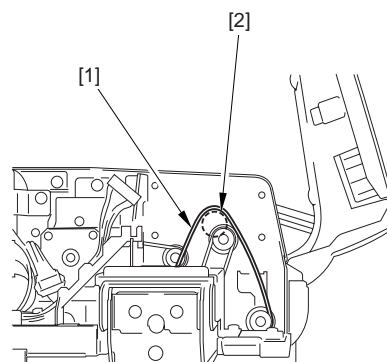

F-3-108

3.4.11.8 Removing the Feed

Guide

0004-5586

1) Open the open/close guide [1]; then, remove the 2 screws [2], and disconnect the connector [3] to detach the feed guide [4].

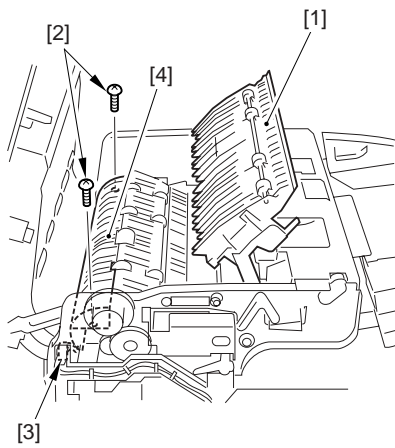

F-3-109

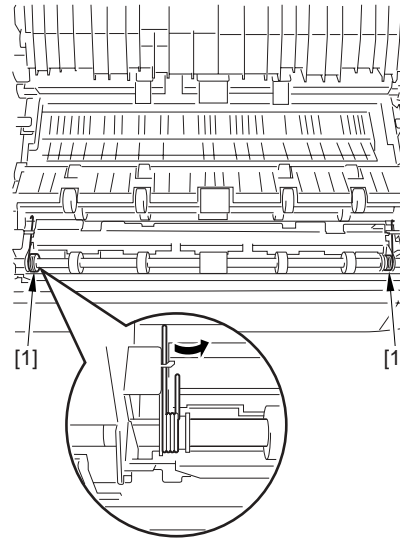

F-3-112

3.4.11.9 Removing the Bushing

Fitted with a Plate

0004-5587

1) Remove the E-ring [1], gear [2], and bushing [3].

4) Remove the 2 E-rings [1].

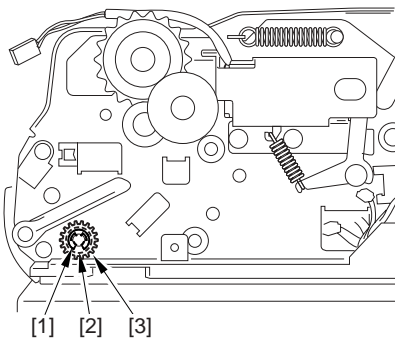

F-3-110

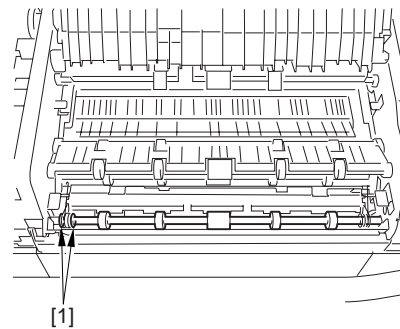

F-3-113

2) Remove the ring [1], gear [2], and busing [3].

5) Slide the bushing [1] fitted with a plate toward the rear, and detach the platen guide [2].

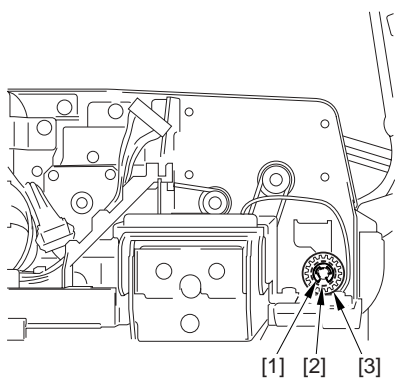

F-3-111

3) Release the pressure spring [1].

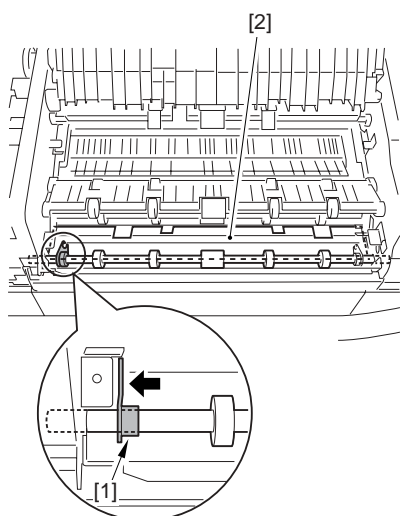

F-3-114

3.4.11.10 Removing the Platen

Upstream Roll

0004-2944

1) Slide the bushing [1] fitted with a plate upward, and pull out the shaft [2]; then, detach the platen upstream roll [3].

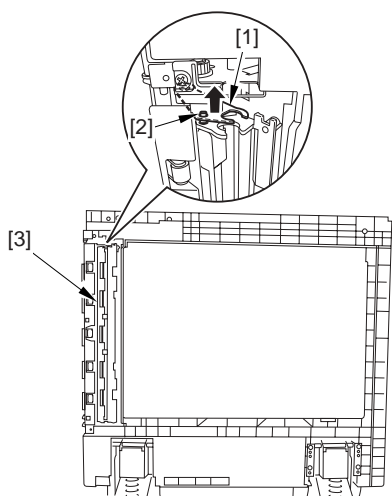

F-3-115

3.4.12 Platen Roller Roll Downstream

3.4.12.1 Removing the Platen

Downstream Roll Unit

0004-0442

1) Remove the screw [1], and detach the platen downstream roll unit [2].

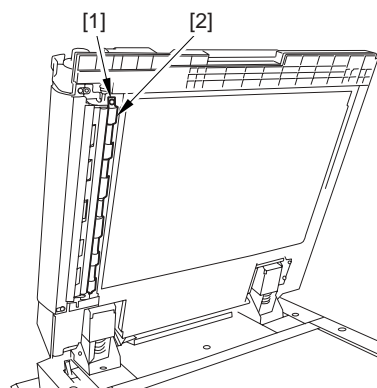

F-3-116

3.4.12.2 Removing the Platen

Downstream Roll

0004-2987

1) Remove the E-ring [1], and pull out the shaft [2]; then, detach the platen downstream roll [3].

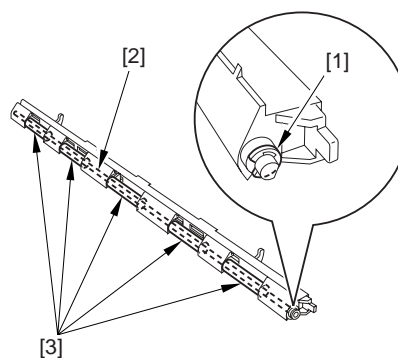

F-3-117

3.4.13 Delivery Reversing Roller (lower)

3.4.13.1 Removing the Inside Cover 0003-5850

1) Open the feeder cover, and remove the 2 screws [1]; then, detach the inside cover [2].

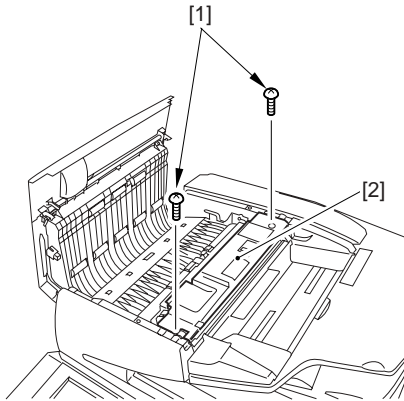

F-3-118

3.4.13.2 Removing the Open/ Close Guide 0004-0732

1) Remove the segment A, and detach the open/close guide [1] in the direction of the arrow.

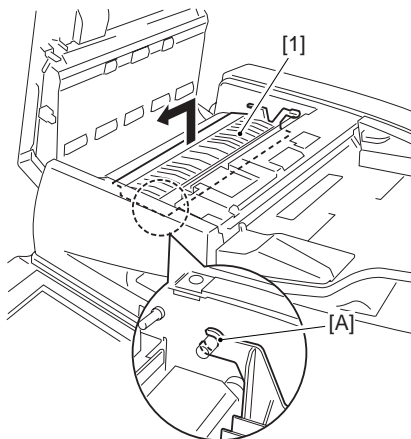

F-3-119

3.4.13.3 Removing the Delivery Reversal Lower Roller 0003-5849

1) Shift up the original pickup tray, and push the delivery reversal lower roller [1] in upward direction to detach.

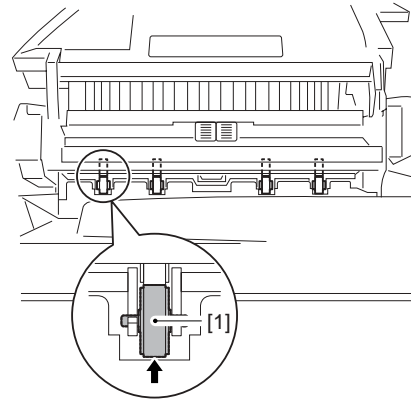

F-3-120

3.4.14 Reversing Roller

3.4.14.1 Removing the Front Cover 0003-8089

1) Remove the 3 screws [1], and detach the front cover [2] by moving it in the direction of the arrow.

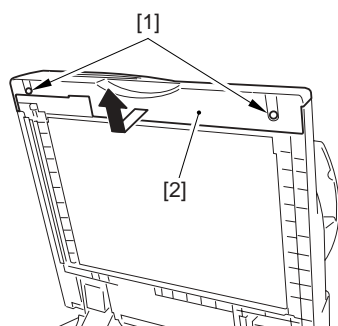
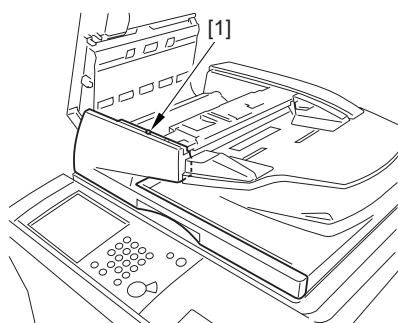

F-3-121

3.4.14.2 Removing the Rear

Cover

0003-8091

1) Open the feeder cover [1] and the original pickup tray [2]; then, remove the 4 screws [3], and detach the rear cover [4].

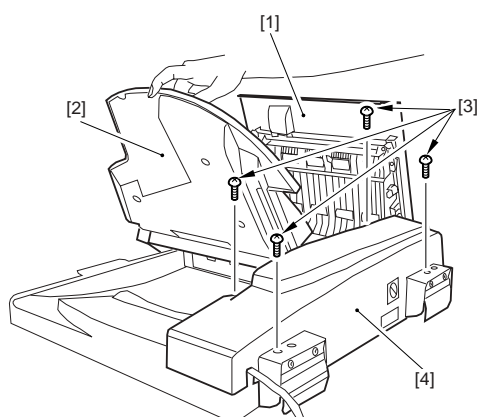

F-3-122

3.4.14.3 Removing the Locking

Motor Harness Guide

0003-8092

1) Remove the screw [1], and disconnect the 3

connectors [2]; then, detach the harness guide [3].

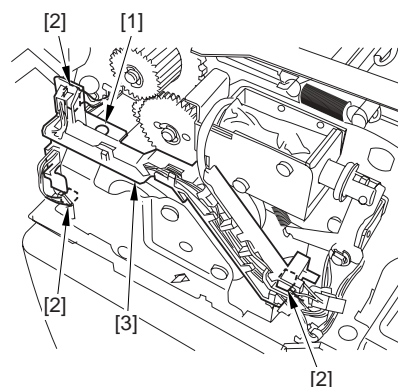

F-3-123

3.4.14.4 Removing the Locking

Motor Drive Unit

0004-0736

1) Remove the 3 screws [1], and disconnect the connector [2]; then, detach the locking motor drive unit [3].

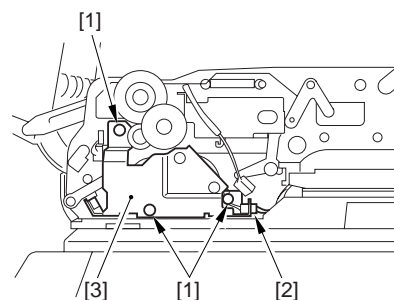

F-3-124

3.4.14.5 Removing the Cooling

Fan

0003-8094

1) Remove the screw [1], and disconnect the connector [2]; then, detach the cooling fan [3].

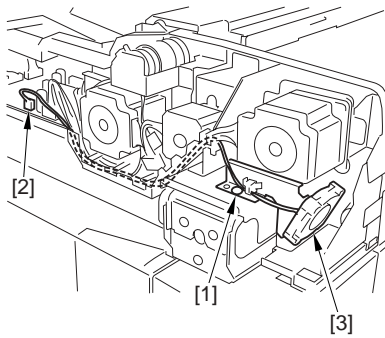

F-3-125

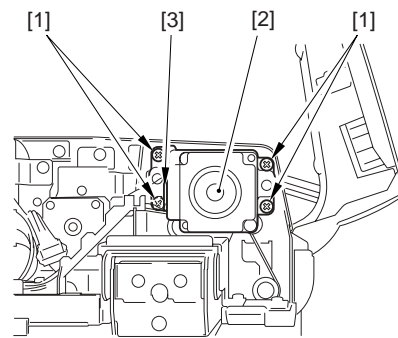

F-3-127

3.4.14.6 Removing the Feed

Motor Unit

0004-0460

1) Loosen the 2 screws [1], and move down the feed motor [2]; then, tighten the 2 screws you have loosened [1].

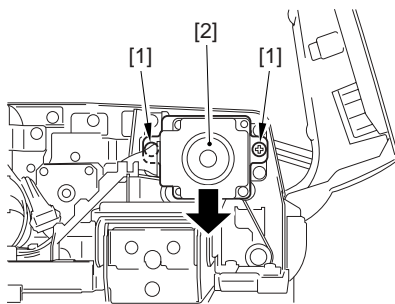

F-3-126

⚠ When mounting it, be sure that the timing belt [1] is properly attached to the pulley [2].

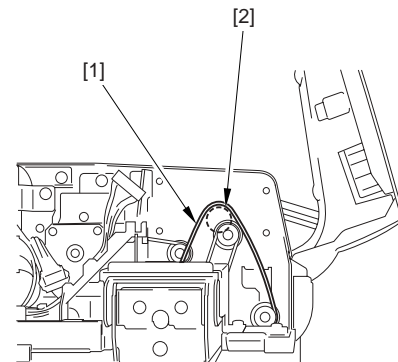

F-3-128

⚠ When mounting it, be sure to loosen the screws [1] and move the feed motor [2] back into its initial position.

2) Remove the 4 screws [1], and disconnect the connector [2]; then, detach the feed motor unit [3].

3.4.14.7 Removing the Reversing Roller

0003-8095

1) Open the open/close guide, and remove the 2 E-rings [1], gear [2], and 2 bushings [3]; then, detach the reversing roller [4].

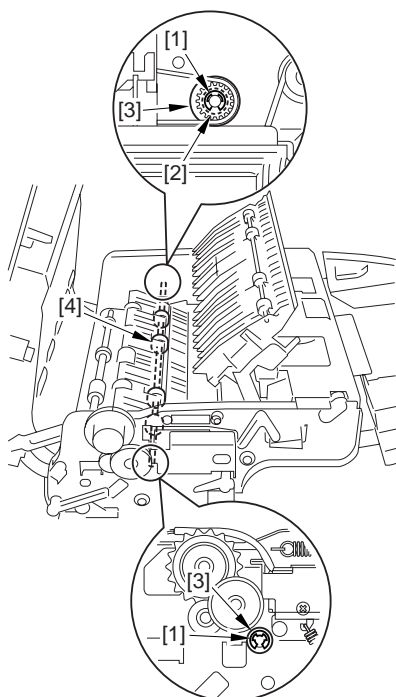

F-3-129

3.4.15 Reversion Roller Roll

3.4.15.1 Removing the Reversing Roll 0003-8087

- 1) Remove the E-ring [1], and detach the reversal roll [2].

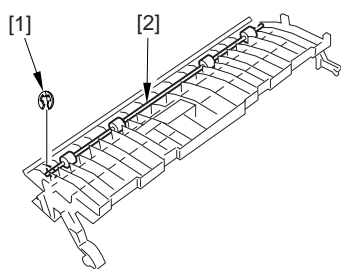

F-3-130

3.4.16 Open/Close Guide Sheet

3.4.16.1 Removing the Open/Close Guide 0004-0730

- 1) Remove the segment A, and detach the open/close

guide [1] in the direction of the arrow.

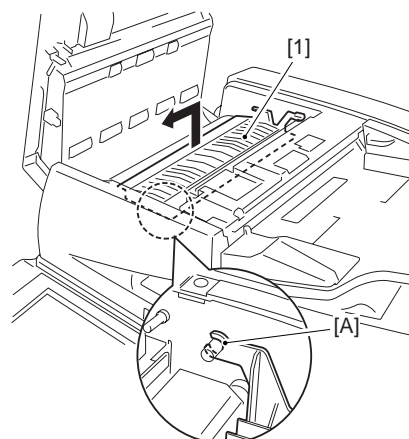

F-3-131

3.4.16.2 Replacing the Open/Close Guide Sheet 0003-8097

- 1) Remove the one/close guide sheet; then, attach it while matching the corners of the sheet and the guide.

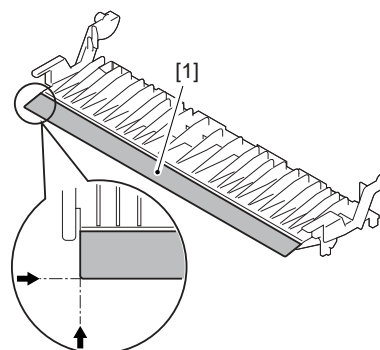

F-3-132

3.4.17 Duct-Collection Sheet

3.4.17.1 Replacing the Dust-Collecting Sheet 0003-8098

- 1) Peel off the dust-collecting sheets [A], [B], [C], [D], and [E]; then, attach the new dust collecting sheets [A], [B], [C], [D], and [E].

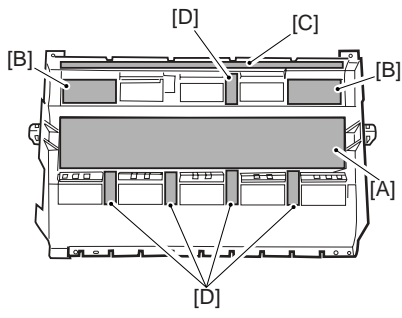

F-3-133

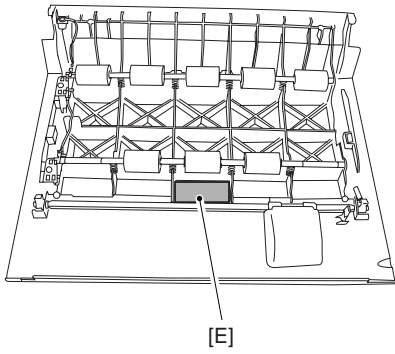

F-3-134

3.5 Electrical System

3.5.1 Fan

3.5.1.1 Removing the Rear

Cover [0004-0741](#)

1) Open the feeder cover [1] and the original pickup tray [2]; then, remove the 4 screws [3], and detach the rear cover [4].

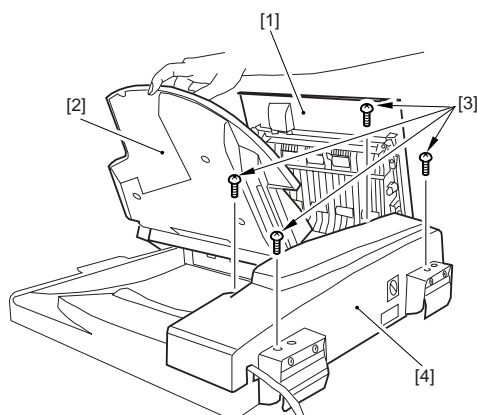

F-3-135

3.5.1.2 Removing the Cooling

Fan [0003-7155](#)

1) Remove the screw [1], and disconnect the connector [2]; then, detach the cooling fan [3].

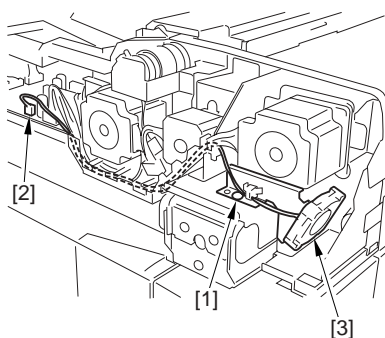

F-3-136

3.5.2 Document Width Volume

3.5.2.1 Removing the Inside

Cover [0004-0489](#)

1) Open the feeder cover, and remove the 2 screws [1]; then, detach the inside cover [2].

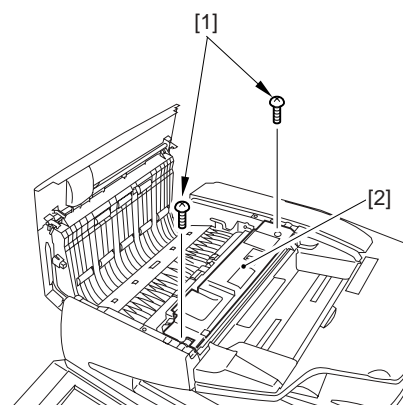

F-3-137

3.5.2.2 Removing the Original Width Volume

[0004-0490](#)

1) Shift up the original pickup tray, and remove the 3 screws [1]; then, detach the original pickup tray cover [2].

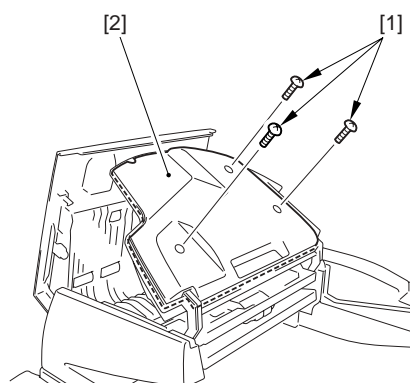

F-3-138

2) Disconnect the 3 connectors [1], and remove the 2 screws [2]; then, detach the original width volume [3].

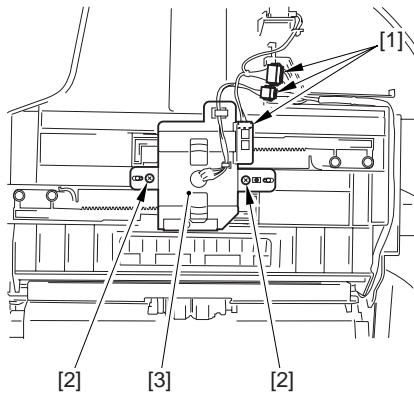

F-3-139

3.5.2.3 Mounting the Original Width Volume

0004-0491

- 1) Move the side guide [1] as wide as possible.

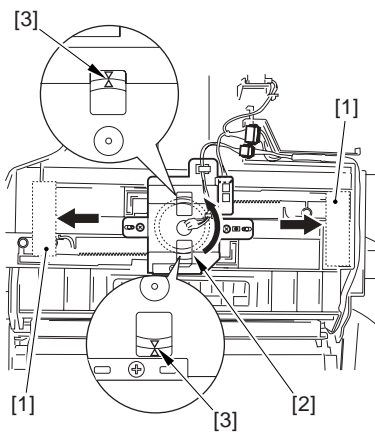

F-3-140

- 2) Turn the gear [2] fully counterclockwise, and mount it so that the arrows [3] match.

⚠ If you have replaced the original width volume, be sure to adjust the position of the side guide plate.

3.5.2.4 Adjusting the Side Guide Plate

0004-9326

Adjusting the Side Guide Plate of the ADF Pickup Tray

- 1) Open the feeder cover, and detach the inside cover.

- 2) Remove the 3 mounting screws [1], and detach the cover [2].

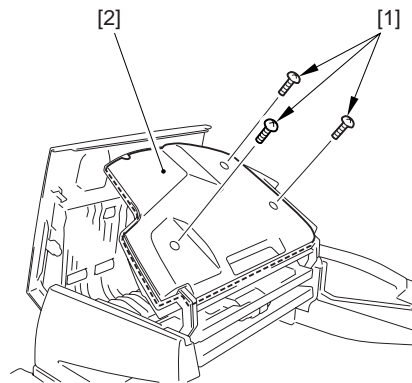

F-3-141

- 3) Loosen the mounting screw [1], and remove the screw [2] from the positioning hole; then, temporarily fit it in the adjusting angular hole [3].

if $A > 1$ mm, move the volume unit [4] toward the front.

if $B > 1$ mm, move the volume unit [4] toward the rear.

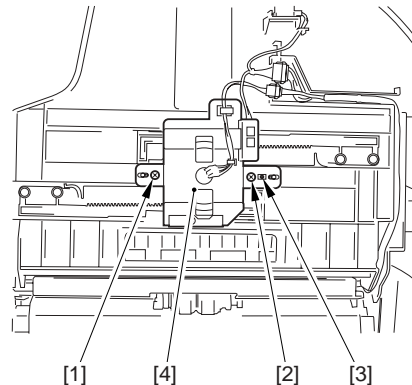

F-3-142

- 4) Move the original width volume [4] toward the front or the rear to make adjustments.
- 5) Tighten the screw [1] you have loosened and the screw you have fitted in the adjusting angular hole [3].
- 6) When done, attach the cover [2].
- 7) Make copies of the Test Chart once again, and check to see that the images are as indicated.

3.5.3 Pressurization Solenoid

3.5.3.1 Removing the Front

Cover 0003-8107

- 1) Remove the 3 screws [1], and detach the front cover [2] by moving it in the direction of the arrow.

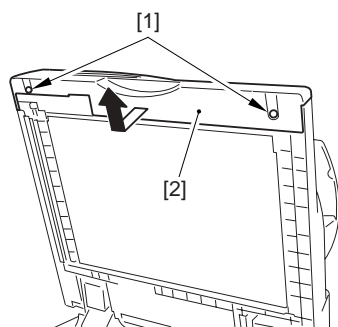
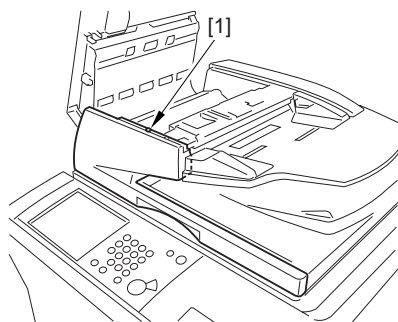

F-3-143

3.5.3.2 Removing the Locking Solenoid

0003-8037

- 1) Remove the 2 screws [1] and the spring [2]; then, detach the locking solenoid [3].

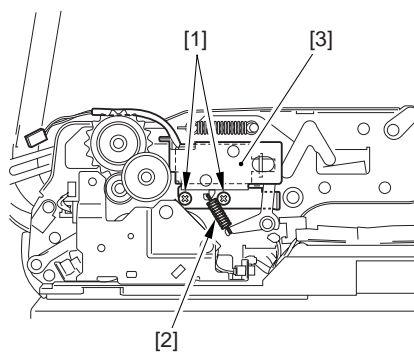

F-3-144

3.5.4 ADF Driver PCB

3.5.4.1 Removing the Rear

Cover 0003-8100

- 1) Open the feeder cover [1] and the original pickup tray [2]; then, remove the 4 screws [3], and detach the rear cover [4].

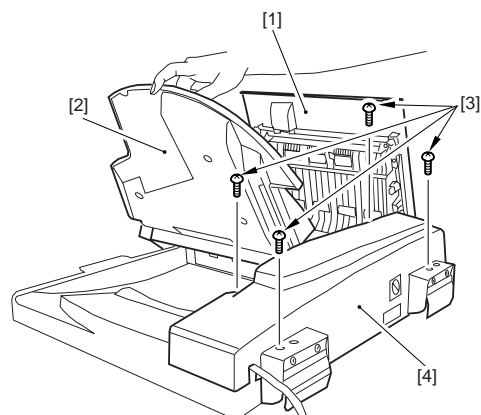

F-3-145

3.5.4.2 Removing the ADF

Driver PCB 0004-0744

- 1) Remove the 3 screws [1], and disconnect the 7 connectors [2]; then, detach the harness guide [3].

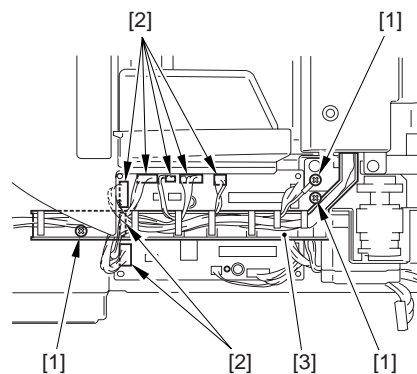

F-3-146

- 2) Disconnect the 5 connectors [1], and remove the 2 screws [2]; then, detach the ADF driver PCB [3].

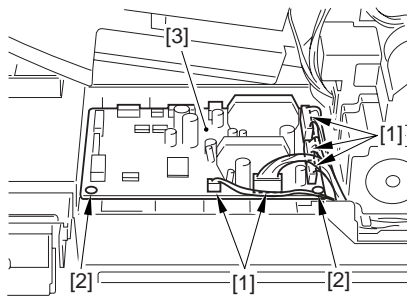

F-3-147

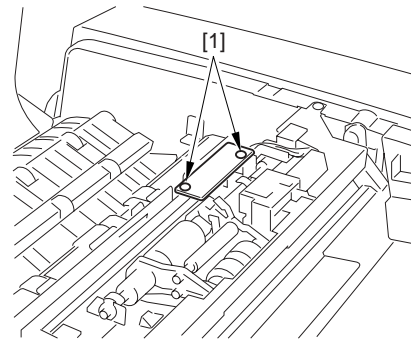

F-3-149

3.5.5 Separation Sensor

3.5.5.1 Removing the Inside

Cover [0004-0518](#)

- 1) Open the feeder cover, and remove the 2 screws [1]; then, detach the inside cover [2].

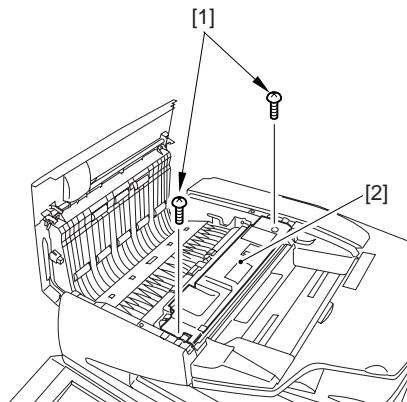

F-3-148

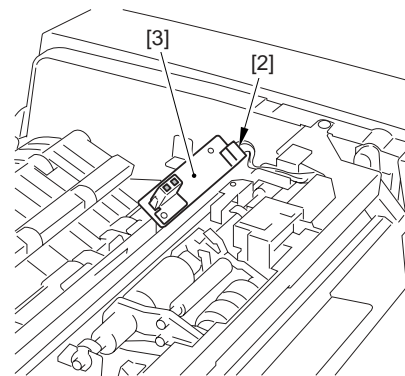

F-3-150

⚠ Be sure to perform sensor adjustment if you have replaced the sensor PCB.

3.5.5.2 Removing the

Separation Read Sensor [0004-0520](#)

- 1) Remove the 2 screws [1], and disconnect the connector [2]; then, detach the separation rear sensor [3].

3.5.6 Read Sensor

3.5.6.1 Removing the Front

Cover [0004-0535](#)

- 1) Remove the 3 screws [1], and detach the front cover [2] by moving it in the direction of the arrow.

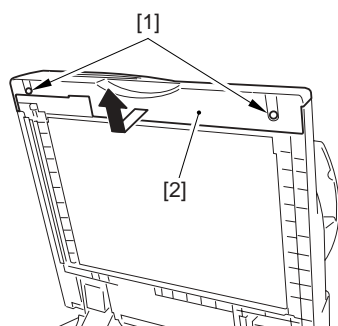
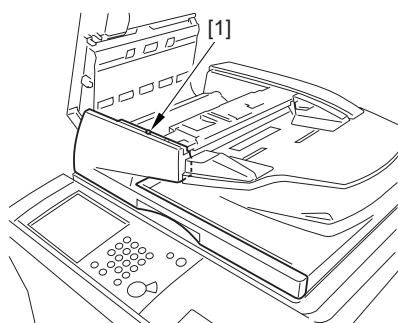

F-3-151

3.5.6.2 Removing the Feed

Guide

0004-5588

1) Open the open/close guide [1]; then, remove the 2 screws [2], and disconnect the connector [3] to detach the feed guide [4].

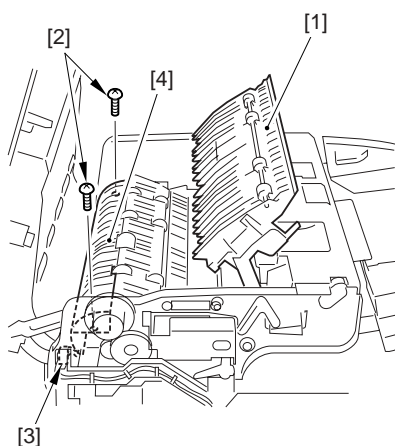

F-3-152

3.5.6.3 Removing the Read

Sensor

0004-0541

1) Remove the 2 screws [1], and disconnect the connector [2]; then, detach the read sensor [3].

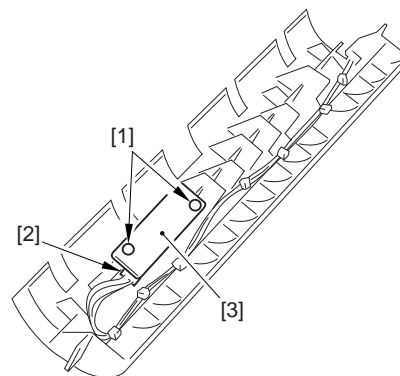

F-3-153

⚠ If you have replaced the sensor PCB, be sure to perform sensor adjustment.

3.5.7 Delivery Reversal Sensor

3.5.7.1 Removing the Open/Close Guide

0004-0731

1) Remove the segment A, and detach the open/close guide [1] in the direction of the arrow.

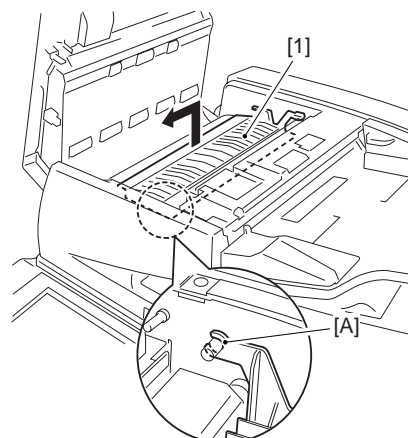

F-3-154

3.5.7.2 Removing the Delivery

Guide

0004-0603

1) Remove the 2 screws [1], and detach the delivery guide [2].

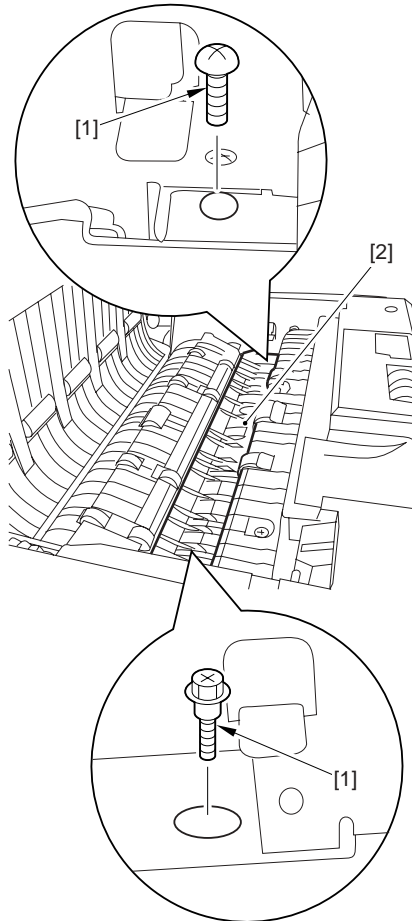

F-3-155

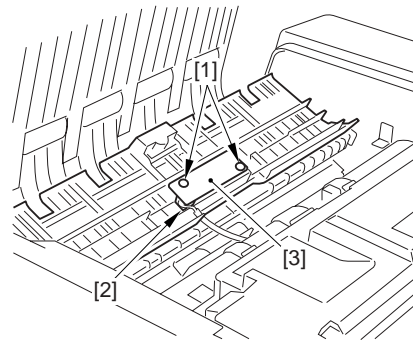

F-3-156

⚠ If you have replaced the sensor PCB, be sure to perform sensor adjustment.

3.5.7.3 Removing the Delivery

Reversal Sensor

0004-8963

1) Remove the 2 screws [1], and disconnect the connector [2]; then, detach the delivery reversal sensor [3].

Chapter 4 Maintenance

Contents

4.1 User Maintenance	4-1
4.1.1 Cleaning	4-1
4.1.2 Replacement	4-2
4.2 Maintenance and Inspection	4-3
4.2.1 Periodically Replaced Parts	4-3
4.2.1.1 Periodically Replaced Parts	4-3
4.2.2 Durables	4-3
4.2.2.1 Durables	4-3
4.2.3 Periodical Servicing	4-4
4.2.3.1 Scheduled Servicing Chart	4-4
4.2.4 Cleaning	4-7
4.2.4.1 Parts of the ADF	4-7
4.2.4.2 Rollers and Guides	4-7
4.2.4.3 Sensors	4-13
4.2.4.4 Applying Silicone Oil to the Reading Glass (copyboard glass)	4-17
4.3 Adjustment	4-20
4.3.1 Basic Adjustment	4-20
4.3.1.1 Overview	4-20
4.3.1.2 Angle Guide (angle of opening at 90 deg)	4-20
4.3.1.3 Sensor Output	4-20
4.3.1.4 Tray Width	4-21
4.3.1.5 Eliminating the Tilt	4-21
4.3.1.6 Height	4-22
4.3.1.7 Right Angle	4-22
4.3.1.8 Angle Guide (angle of opening of 70 deg)	4-23
4.3.1.9 Magnification	4-24
4.3.1.10 Horizontal Registration	4-25
4.3.1.11 Leading Edge Registration	4-26
4.3.1.12 White Level	4-27
4.3.1.13 Adjusting the Hinge Pressure	4-27
4.3.2 Adjustment at Time of Parts Replacement	4-27
4.3.2.1 Overview	4-27
4.3.2.2 After Replacing the Reader Controller PCB	4-28
4.4 Outline of Electrical Components	4-30
4.4.1 Sensors	4-30
4.4.2 Motors, Clutches, Solenoids, PCBs, and Others	4-31
4.5 Variable Resistors (VR), Light-Emitting Diodes (LED), and Check Pins by PCB	4-33
4.5.1 Overview	4-33
4.5.2 ADF Driver PCB	4-33
4.5.3 Original Placement led PCB	4-33

4.1 User Maintenance

4.1.1 Cleaning

0002-9919

Advise the user to clean the following parts as necessary or every 10,000 prints without fail.

T-4-1

Parts	Method	Intervals	Remarks
Copyboard glass	Wipe it with a cloth moistened with water (well wrung) or solution of mild detergent: then, dry wipe it.	As necessary	Reader unit parts
Platen roller			
Copyboard glass retainer			Reader unit parts
White plate (copyboard cover)			
Vertical size plate			Reader unit parts
Original stream reading glass			Reader unit parts

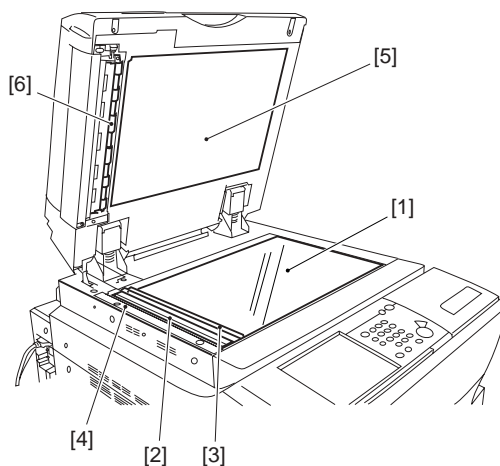

F-4-1

T-4-2

[1]	Copyboard glass
[2]	Original stream reading glass
[3]	Vertical size plate

[4]	Original glass retainer
[5]	White plate (copyboard cover)
[6]	Platen roller

4.1.2 Replacement

0003-0121

1. Replacing the Stamp

1) Open the feeder cover and the open/close guide.

2) Using tweezers, fit the new stamp in place.

Make sure that the printing side faces upward.

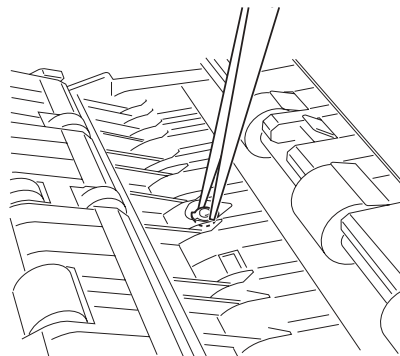

F-4-2

⚠ Be sure to push in the stamp until a click is felt. A gap can cause paper jams.

4.2 Maintenance and Inspection

4.2.1 Periodically Replaced Parts

4.2.1.1 Periodically Replaced Parts

0003-1674

The machine does not have parts that must be replaced on a periodical basis.

4.2.2 Durables

4.2.2.1 Durables

0003-1675

Some parts of the machine may have to be replaced once or more over the period of product life because of wear or damage. Replace them when they fail, using the following table as a guide; the number of originals the machine has picked up may be checked using the host machine's service mode:

T-4-3

No	Parts name	Parts No.	Q'ty	Lifetime
1	Pickup roller	FC3-0722	1	80,000 originals
2	Separation Base	FL2-0748	1	80,000 originals
3	Feed Roller	FC5-3155	1	80,000 originals
4	Separation pad	FL2-0749	1	80,000 originals
5	Dust-colleting tapeA	FC5-2959	1	80,000 originals
6	Dust-colleting tapeB	FC5-2960	1	80,000 originals
7	Dust-colleting tapeC	FC5-2961	1	80,000 originals
8	Dust-colleting tapeD	FC5-3016	2	80,000 originals
9	Dust-colleting tapeE	FC5-3017	5	80,000
10	Stamp(option)	FB5-9410	1	7,000 originals

⚠ Expected service life shows the central value of a group of evaluation data points. Parts Numbers may subject to change because of design

4.2.3 Periodical Servicing

4.2.3.1 Scheduled Servicing Chart

0003-1677

⚠ Do not use solvents or oils other than those indicated.
Be sure to clean the rollers and scrapers, as the presence of paper lint or dust on them can cause lines in images.

A: clean B: lubricate C: replace D: adjustment

T-4-4

No	Parts name	Servicing*1	
		80,000 originals or 6 months	160,000 originals or 12 month
1	White plate (copyboard cover)	A	
2	Post-separation sensor (prism)		A
3	Read sensor (prism)		A
4	Delivery reversal sensor (prism)		A
5	No. 1 registration roller	A	
6	No. 1 registration roll	A	
7	No. 2 registration roller	A	
8	No. 2 registration roll	A	
9	Read roller 1	A	
10	Read roll 1	A	
11	Platen roller	A	
12	Platen upstream roll	A	
13	Platen downstream roll	A	

No	Parts name	Servicing*1	
		80,000 originals or 6 months	160,000 originals or 12 month
14	Read roller 2	A	
15	Read roll 2	A	
16	Reversing roll	A	
17	Reversing roller	A	
18	Delivery reversing upper roller	A	
19	Delivery reversing lower roller	A	
20	Original pickup tray	A	
21	Open/close guide (including sheets)	A	
22	Delivery guide	A	
23	Reversing guide	A	
24	Pre-registration guide (including sheets)	A	
25	Feed guide	A	
26	Reversing flapper	A	
27	White plastic film	A	
28	Dust-colleting tape	C	
29	Reading glass*2	B	
30	DADF height (See the Adjustment Procedure.)	D	
31	Roll scraper	A	

*1: the actual number of originals the machine has handled may be checked using its host machine's service mode: COPIER>COUNTER>FEEDER>FEED.

*2: apply silicone oil.

The following diagram shows the arrangement of the parts that need to be serviced on a periodical basis:

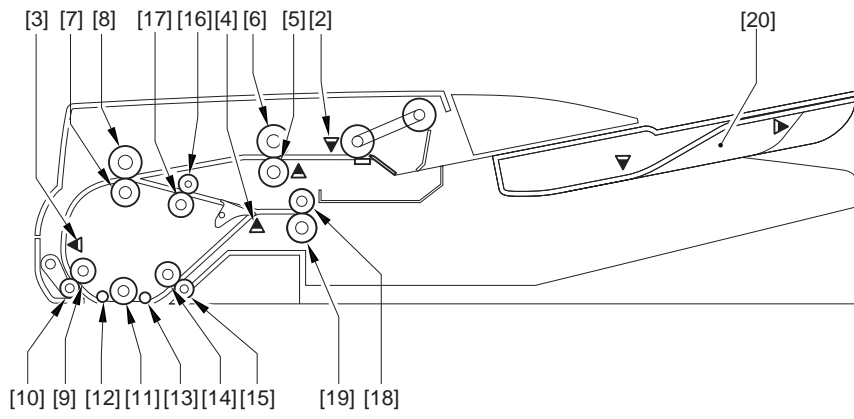

F-4-3

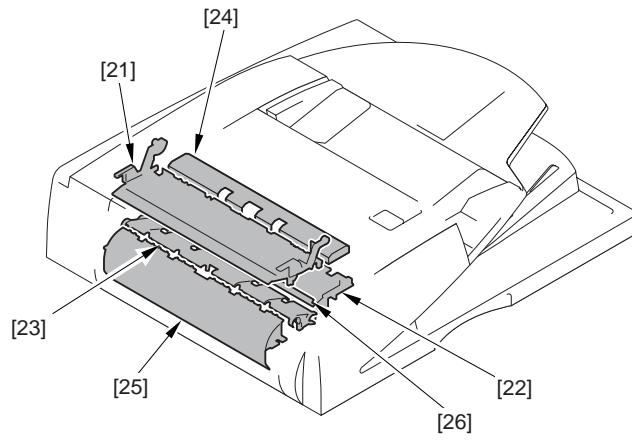

F-4-4

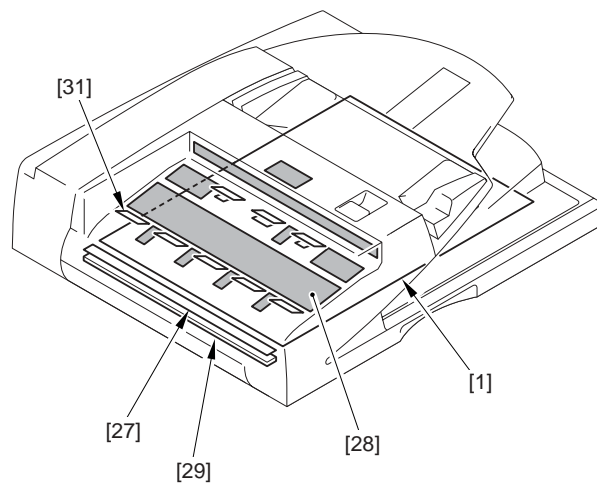

F-4-5

4.2.4 Cleaning

4.2.4.1 Parts of the ADF

0003-1690

1. Platen Roller, Platen Upstream Roll, and Platen Downstream Roll

Wipe the platen roller [1] platen upstream roll [2], and platen downstream roll [3] with a cloth moistened with water (well wrung); then, dry wipe them.

2. White Plastic Film

Wipe the white plastic film [4] with a cloth moistened with water (well wrung) or alcohol; then, dry wipe it.

3. White Plate (copyboard)

Wipe the white plate [5] with a cloth moistened with water or alcohol; then, dry wipe it.

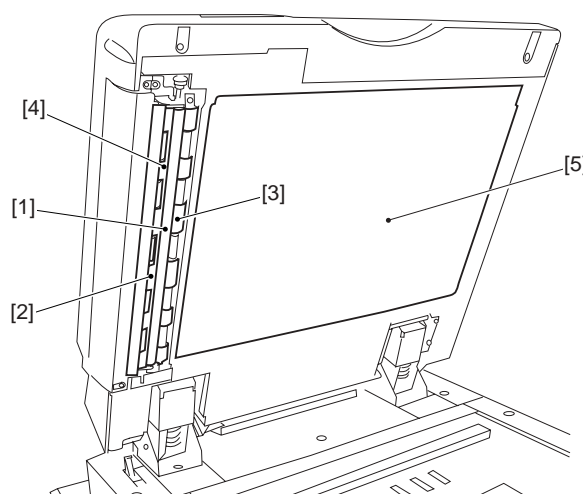

F-4-6

[1] Platen roller

[2] Platen upstream roll

[3] Platen downstream roll

[4] White plastic film

[5] White plate (copyboard cover)

4.2.4.2 Rollers and Guides

0003-1708

1. Original Pickup Tray

Wipe the original pickup tray [1] with lint-free paper moistened with alcohol.

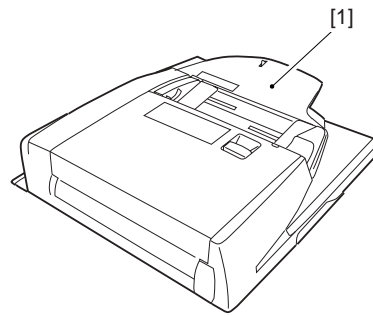

F-4-7

2. Open/Close Guide (including sheets) and Reversing Roll

- 1) Open the feeder cover, and detach the open/close guide.
- 2) Wipe the area of the open/close guide (including sheets) [1] coming into contact with paper and the reversing roll [2] found behind the open/close guide with lint-free paper moistened with alcohol.

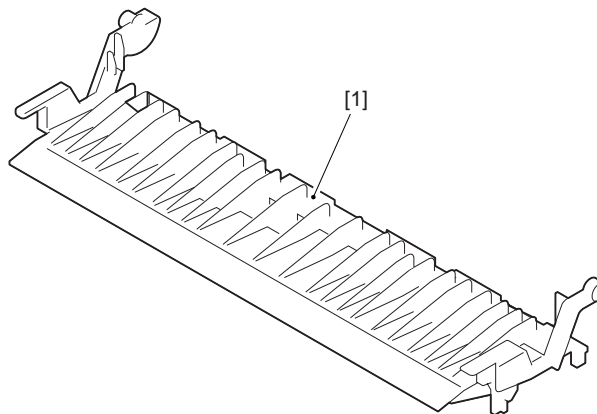

F-4-8

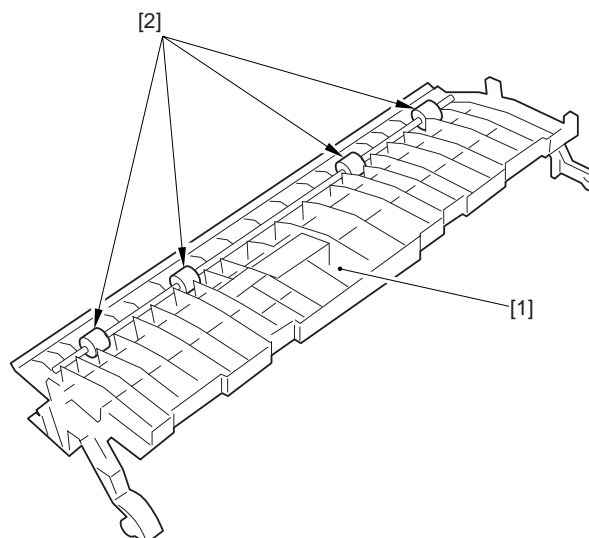

F-4-9

3. No. 1 Registration Roller, No. 2 Registration Roller, No. 1 Registration Roll, No. 2 Registration Roll, and Reversing Roller.

1) Clean the following in the order indicated: platen roller, No. 1 registration roll [1], No. 1 registration roller [2], No. 2 registration roll [3], No. 2 registration roller [4], reversing roller [5].

1. make the following selections in service mode to highlight [ROLL-CLN], and press the OK key to rotate the rollers: FEEDER>FUNCTION>ROLL-CLN.

2. force lint-free paper moistened with alcohol against the rollers to clean them.

3. press the OK key to stop the rollers.

Memo:

The No. 1 registration roller and the No. 2 registration roller will not rotate even when the foregoing service mode is executed (i.e., FEEDER>FUNCTION>ROLL-CLN).

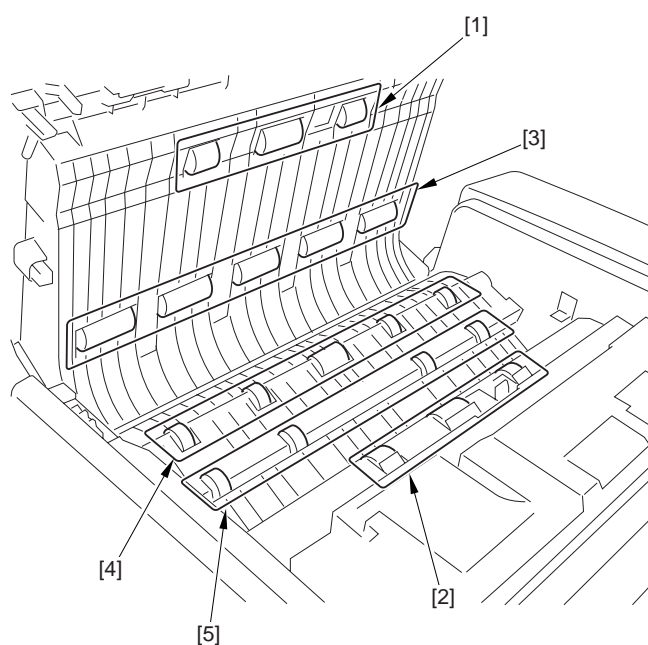

F-4-10

2) Clean the feeder inside cover [1], feed guide [2], reversing guide [3], delivery guide [4], and registration guide [5] (including sheets) with lint-free paper moistened with alcohol.

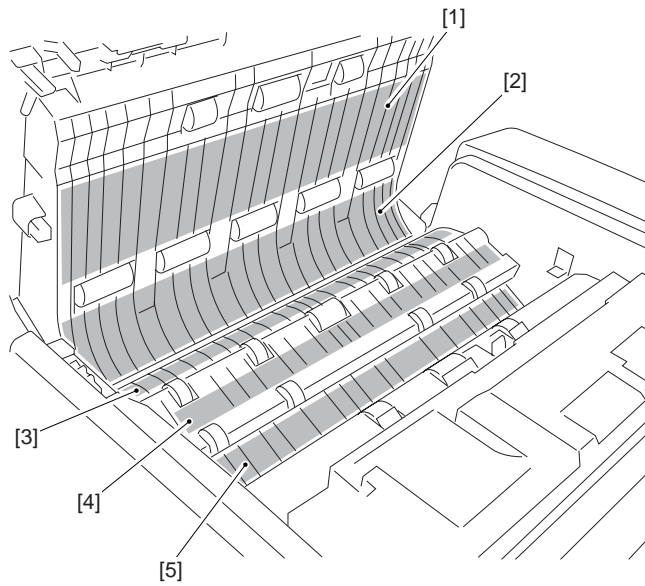

F-4-11

3) Remove the feeder cover and the feeder inside cover; then, clean the roll scraper [1] with lint-free paper moistened with alcohol.

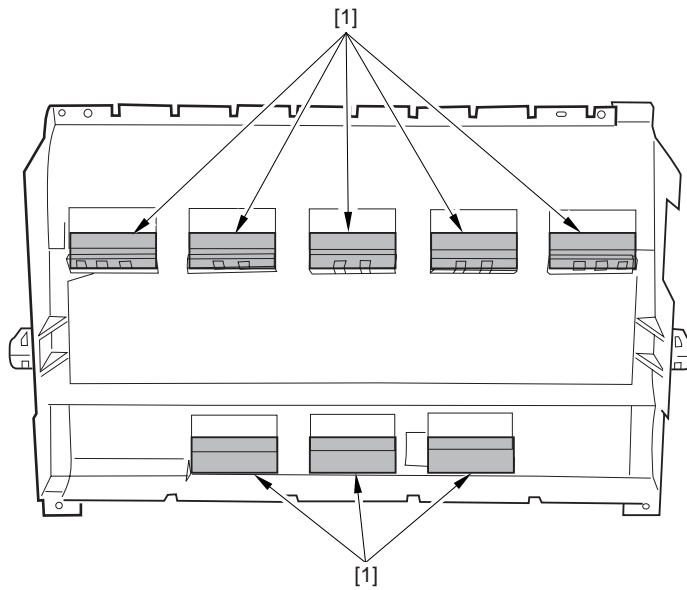

F-4-12

4. Read Roller 1 and Read Roller 2

- 1) Remove the 3 screws, and detach the front cover.
- 2) Detach the feeder cover.
- 3) Disconnect the connector [1], and remove the 2 screws [2]; then, detach the feed guide [3].

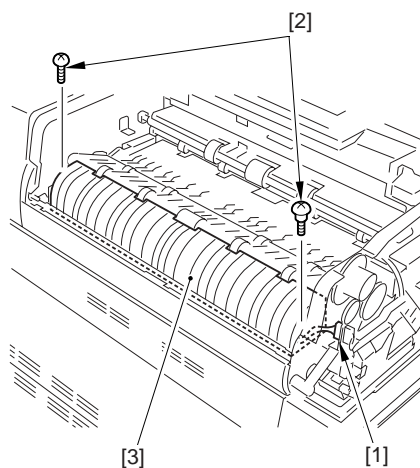

F-4-13

4) Clean the red roller 2 [1] and the read roller [2] with lint-free paper moistened with alcohol.

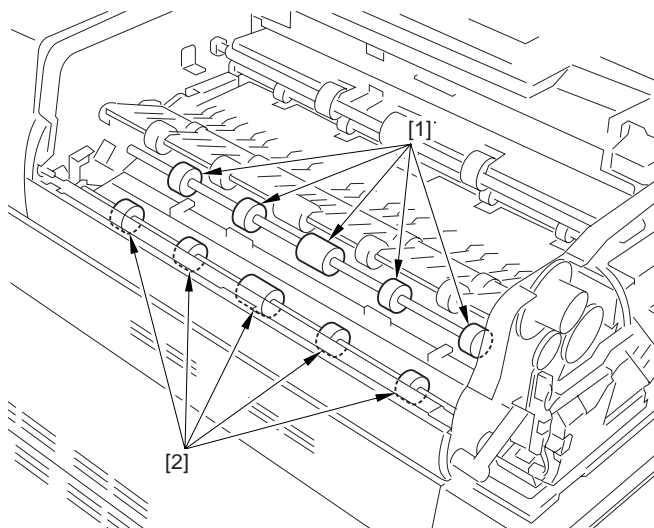

F-4-14

5. Delivery Reversing Upper Roller and Delivery Reversing Lower Roller

- 1) Open the feeder cover; then, remove the 2 screws, and detach the inside cover.
- 2) Shift up the original pickup tray, and clean the delivery reversing lower roller [1] and the delivery reversing upper roller [2] with lint-free paper moistened with alcohol.

⚠ Take care so that the lint-free paper will not touch the tip of the static eliminator.

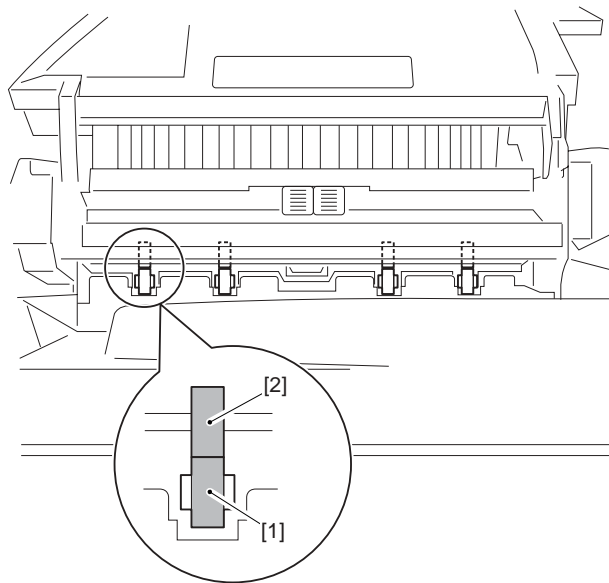

F-4-15

3) When done, mount back the inside cover.

6. Read Roll and Roll Scraper

1) Remove the lower left cover.

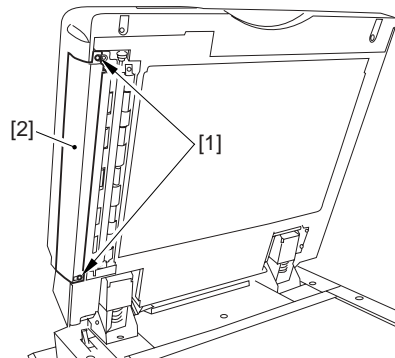

F-4-16

2) Clean the read roll [1] and the roll scraper [2] with lint-free paper moistened with alcohol.

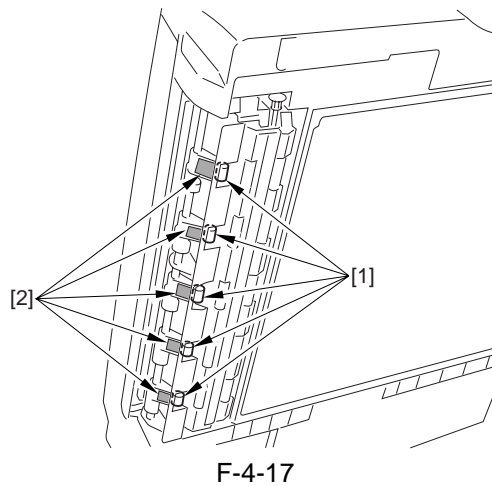

7. Reversing Flapper

- 1) Open the feeder cover and the open/close guide.
- 2) Clean the area of the reversing flapper [1] coming into contact with paper using lint-free paper moistened with alcohol.

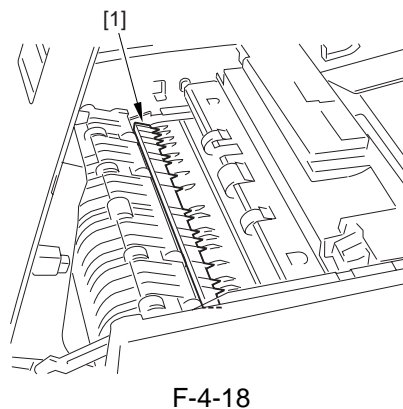

4.2.4.3 Sensors

0003-2455

1. Delivery Reversal Sensor, Prism

- 1) Open the feed cover.
- 2) Remove the open/close guide.
- 3) Clean the prism [1] found on the back of the open/close guide using an air blower brush.

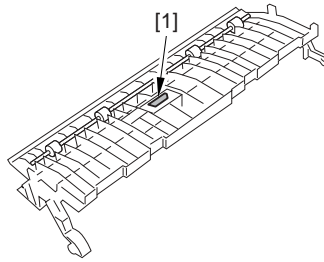

F-4-19

- 4) Remove the delivery guide.
- 5) Remove the 2 screws, and detach the delivery reversal sensor; then, clean the delivery reversal sensor and the reflecting sheet using an air blower brush.

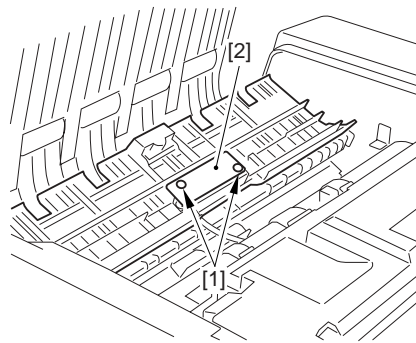

F-4-20

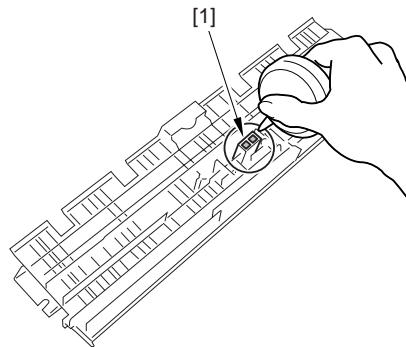

F-4-21

2. Read Sensor, Prism

- 1) Remove the feed cover.
- 2) Remove the feed guide.
- 3) Remove the 2 screws, and detach the read sensor; then, clean the read sensor using an air blower brush.

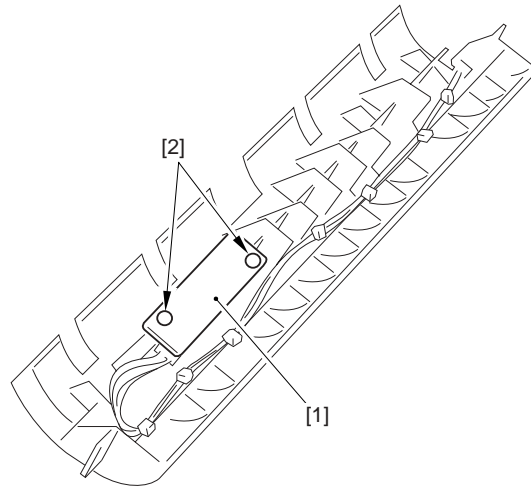

F-4-22

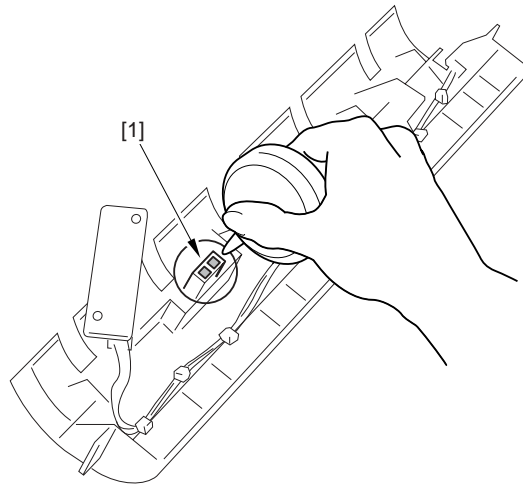

F-4-23

4) Clean the top face (plastic film) [1] of the prism.

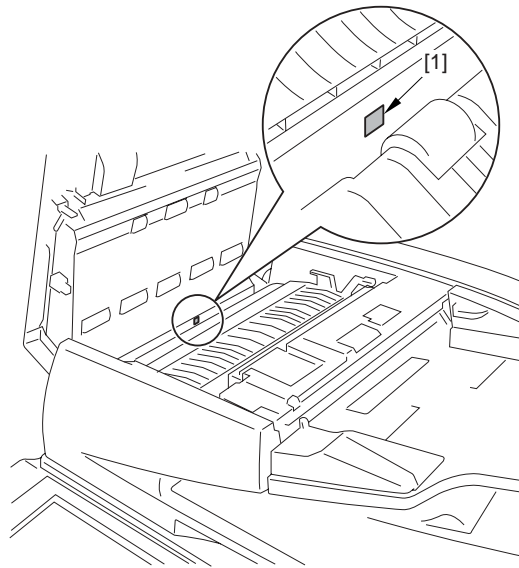

F-4-24

⚠ The surface of the prism coming in contact with paper is covered with plastic film. Be sure to clean the film.

3. Post-Separation Sensor, Prism

- 1) Remove the inside cover.
- 2) Remove the 2 screws [1], and detach the post-separation sensor [2]; then, clean the post-separation sensor using an air blower brush.

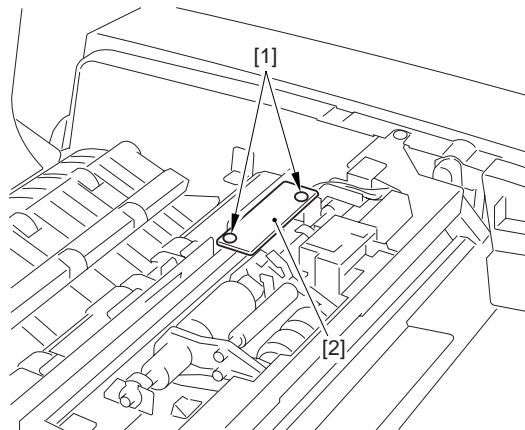

F-4-25

- 3) Clean the prism [1] using a cotton swab.

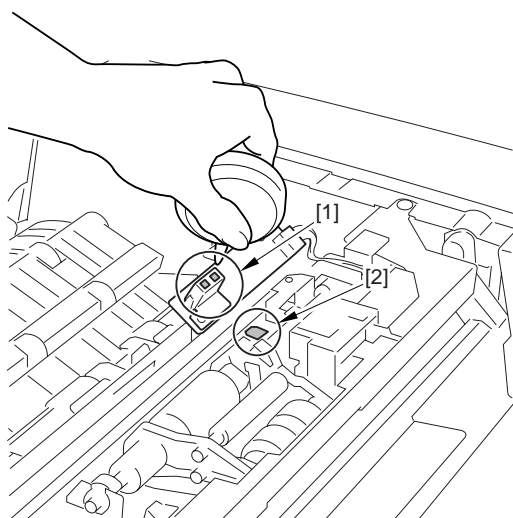

F-4-26

4.2.4.4 Applying Silicone Oil to the Reading Glass (copyboard glass)

0003-2473

1. Tools to Prepare

- i. silicone oil



F-4-27

- ii. cleaning tissue

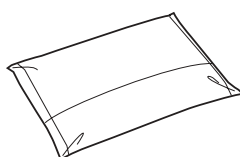

F-4-28

Memo:

silicone oil: FY9-6013-000

cleaning tissue: FC5-4430-000

2. Before Starting the Work

- 1) Clean the reading glass.
 - Dry wipe the reading glass [1] using cleaning tissue.

⚠ At this print, avoid moistening the cleaning tissue with silicone oil.

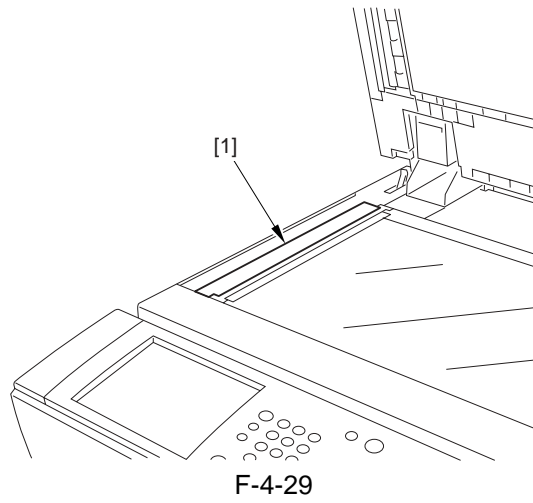

3. Applying the Silicone Oil

1) Squeeze the silicone oil bottle [1] 2 to 3 times, thereby moistening cleaning tissue [2] with an appropriate amount of it.

⚠ Avoid inhaling the vapor of the oil.

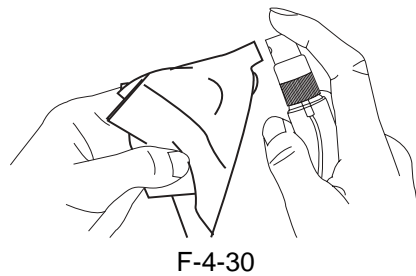

2) Apply the silicone oil to the reading glass [1] with the cleaning tissue.

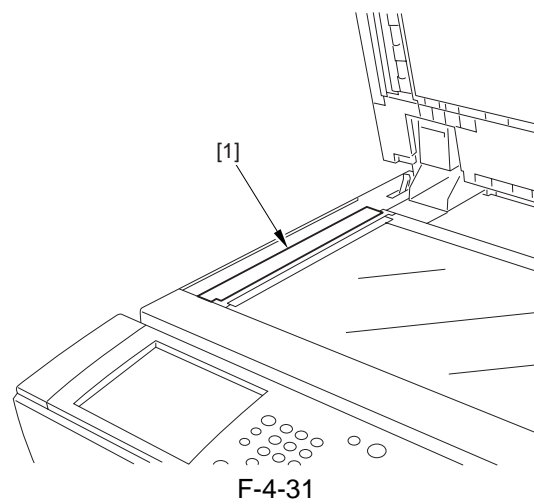

4. Dry Wiping

- 1) Using a fresh area of the cleaning tissue (i.e., free of silicone oil), dry wipe the reading glass.

4.3 Adjustment

4.3.1 Basic Adjustment

4.3.1.1 Overview

0003-1634

The machine's basic adjustments must be made in the following order:

- [1] angle guide (angle of opening at 90 deg)
- [2] tray width*1
- [3] sensor output*1
- [4] tilt
- [5] height
- [6] right angle
- [7] angle guide (angle of opening at 70 deg)
- [8] magnification*1
- [9] horizontal registration*1
- [10] leading edge registration*1
- [11] white level*1

*1: adjustment made using the host machine's service mode.

Memo:

Be sure to make these basic adjustments whenever you have detached the machine or replaced any of the parts indicated.

4.3.1.2 Angle Guide (angle of opening at 90 deg)

0003-1796

Adjust the angle of opening. If it is 90 deg, go to the next item of adjustment (i.e. tray width).

- 1) Bend over the edge of the rubber cover [1], and remove the 2 mounting screws [2]; then, detach the angle guide plate [3].

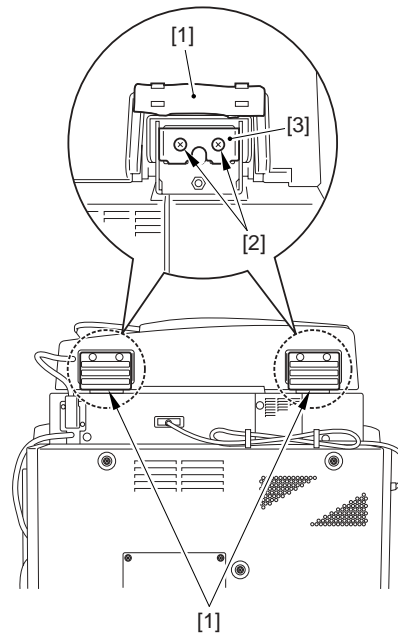

F-4-32

4.3.1.3 Sensor Output

0004-9325

Make the following adjustments if you have replaced any of the following parts:

- reader controller PCB
- post-separation sensor (PI7)
- read sensor (PI8)
- delivery reversal sensor (PI9)

⚠ If you have replaced any of the sensors (i.e., PI7, PI8, PI9), be sure to clean the surface of the prism before starting to make the adjustments.

Adjustment Procedure

- 1) Turn on the host machine, and start its service mode.

<Starting Service Mode>

Press the User Mode key; press the 2 and 8 keys at the same time; then, press the user Mode key once again.

⚠ Check to be sure that there is no paper inside the ADF before starting the adjustments.

2) Make the following selections to highlight [SENS-IN]; FEEDER>FUNCTION>SENS-IN.

3) Press the OK key.

In response, the machine will run an automatic adjustment session, and will indicate 'OK!' if it ends normally.

4) When done, end service mode.

4.3.1.4 Tray Width 0003-3042

 To adjust the tray width, go through the steps under either "1. AB-Configuration" or "2. Inch-Configuration."

1. AB-Configuration

1) Turn on the host machine, and start its service mode.

<Starting Service Mode>

Press the User Mode key; press the 2 and 8 keys at the same time; then, press the User Mode key once again.

2) Touch the following in sequence on the screen to bring up the Adjustment screen: FEEDER>FUNCTION>TRY-A4.

3) Move the tray side guide to the index A4/A3.

4) Press the OK key to register the A4 width.

5) Move the tray side guide to the index A5R.

6) Touch [TRY-A5R] to highlight.

7) Move the tray side guide to the index A5R.

8) Press the OK key to register the A5R width.

9) Press the Reset key twice to end service mode.

10) Turn off the host machine's control panel power switch and main power switch in sequence.

11) Turn on the host machine's main power switch.

2. Inch-Configuration

1) Turn on the host machine, and start its service mode.

<Service Mode>

Press the User Mode key, and press the 2 and 8 keys at the same time; then, press the User Mode key once again.

2) Touch the following in sequence on the screen to bring up the Adjustment screen: FEEDER>FUNCTION>TRY-LTR.

3) Move the tray side guide to the index LTR/11x17.

4) Press the OK key to register the LTR width.

5) Touch [TRY-LTRR] to highlight.

6) Move the tray side guide to the index STRM/LTRR/LGL.

7) Press the OK key to register the LTRR width.

8) Press the Reset key twice to end service mode.

9) Turn off the host machine's control panel power switch and main power switch in sequence.

10) Turn on the host machine's main power switch.

4.3.1.5 Eliminating the Tilt 0003-1846

 Be sure you have adjusted the angle of the ADF before starting the following adjustment:

1) Loosen the nut [1] found at the rear of the left hinge; then, turn the hex bolt [2] so that the fixing member [3] is as far as the line marking [4].

- turn the bolt clockwise to move the member ahead.

- turn the bolt counterclockwise to move the member in reverse.

2) Tighten the nut.

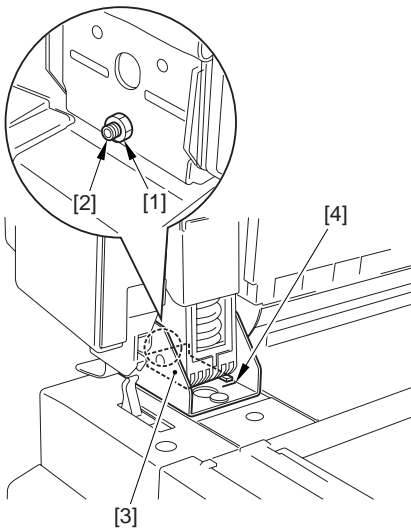

F-4-33

4.3.1.6 Height

0003-1849

- 1) With the machine closed, check to see if the height adjusting rolls [1] found at the left rear and front are in contact with the reading glass [2].

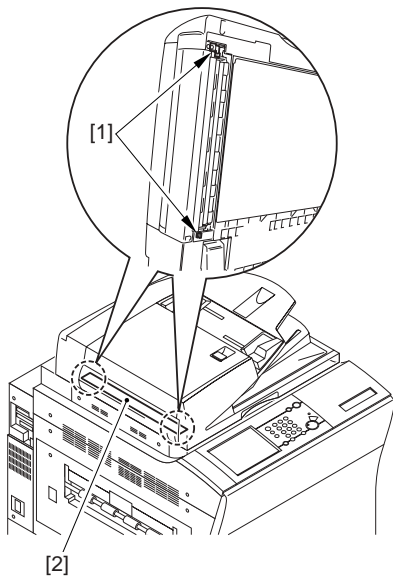

F-4-34

Memo:

To facilitate the work, try executing the following to turn on the scanning lamp using the host machine's service mode: COPIER>FUNCTION>MISC-

R>SCANLAMP.

<If Not in Contact>

If the height adjusting rolls [1] at the left front and rear are not in contact with the reading glass [2], turn the fixing screw [3] found at the top of the left hinge.

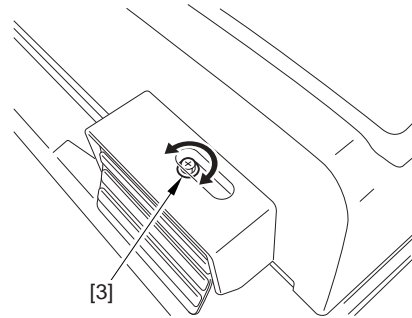

F-4-35

4.3.1.7 Right Angle

0003-2252

The following steps adjust the relationship between the machine's original feed direction and the host machine's scanner system:

- 1) Place the Test Chart in the machine, and make a copy.
- 2) Check the right angle of the image in relation to the leading edge of the output (i.e., angle A).

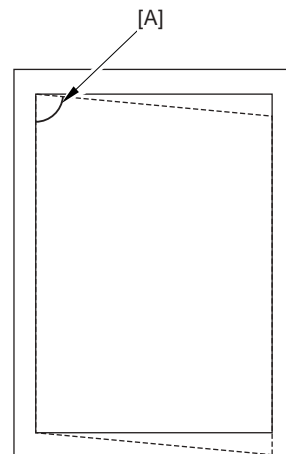

F-4-36

- 3) Loosen the 2 knurled screws found at the front of the right hinge unit.

- 4) Bend over the edge of the rubber cover [2] found at

the rear of the right hinge unit, and loosen the fixing nut [3]; make adjustments using the bolt with a hex hole [4].

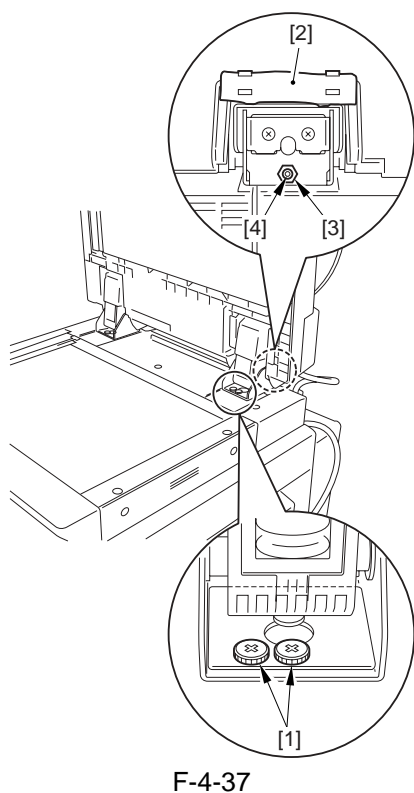

F-4-37

- if $A > B$ (less than 90 deg), turn the bolt clockwise.
- if $A < B$ (90 deg or more), turn the bolt counterclockwise.

5) After adjustment, tighten the nut to fix the bolt with a hex hole [3] in place.

6) Place the Test Chart in the machine once again, and make a copy; then, check to see that the angle is a right angle.

If the following image appears after adjusting the right angle (i.e., if paper moves askew), go to the next adjustment to remove the skew (registration roller). In principle, the foregoing adjustment should correct the angle.

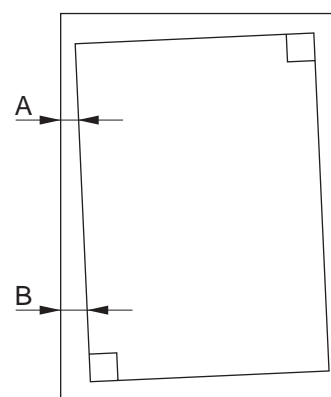

F-4-38

7) Remove the screw [1], and fit it and temporarily tighten it in the screw hole [2].

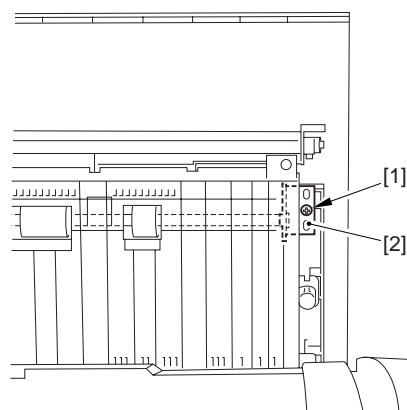

F-4-39

- if $A > B$, move up the plate [1] to make adjustments.
- if $A < B$, move down the place [1] to make adjustments.

8) When done, move back the screw [1] to its initial hole, and tighten it fully.

9) Make a copy of the Text Chart, and make sure that the angle is a right angle by comparing the output and the Test Chart.

4.3.1.8 Angle Guide (angle of opening of 70 deg)

0003-2278

Adjust the angle of opening as follows:

1) Bend over the edge of the rubber cover [1], and mount the angle guide plate [3] in place using 2

screws [2].

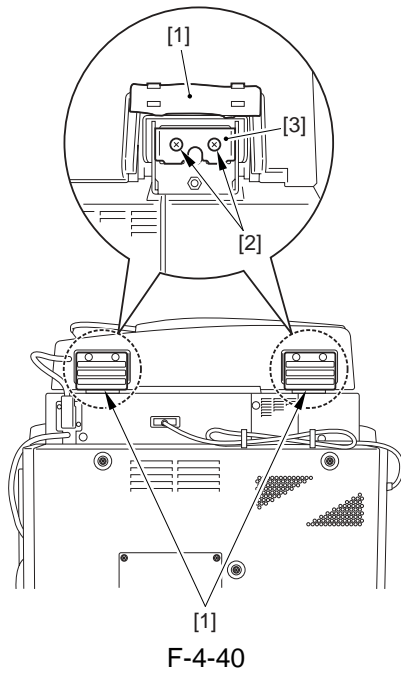

4.3.1.9 Magnification

0003-2302

Memo:

To adjust the magnification, compare an image made in stream reading mode and an image made in copyboard mode. Unlike other ADFs, you will not be comparing a copy image and its original.

1) Using A4 or LTR paper, prepare a test chart as follows:

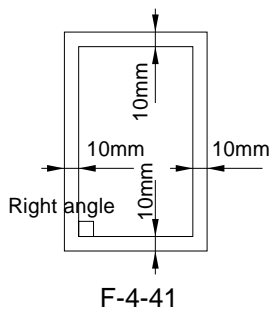

2) Place the test chart you have prepared on the copyboard glass, and make a copy. Refer to the output as copy A.

3) Place the test chart in the original pickup tray, and make a copy at a 100% reproduction ratio. Refer to the output as copy B.

4) Put copy A and copy B together, and compare the length of the image in feed direction, making sure that dimension a is as indicated. If not, go to step 5).

standard: $a \leq 1 \text{ mm}$

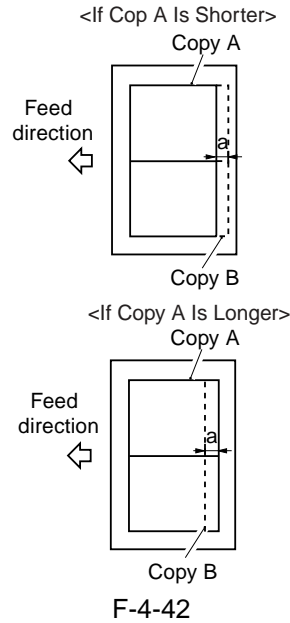

5) Start service mode as follows: press the User Mode key, press the 2 and 8 keys at the same time, and press the User Mode key once again.

6) Make the following selections: FEEDER>ADJUST>LA-SPEED; then, change the setting to make adjustments.

- if the image on copy A is longer, decrease the setting (so that the speed of stream reading is increased).

- if the image on copy A is shorter, increase the value (so that the speed of steam reading is decreased).

(unit: 0.1%)

[range -30 to 30 : -3 to + 3 %]

7) Make a copy of the text charge once again, and check to see that the image is as indicated.

4.3.1.10 Horizontal

Registration

0003-2279

Memo:

If the image is still not indicated after making adjustments using the host machine's service mode, adjust the side guide plate of the ADF original pickup tray.

a. Making Adjustments Using the Host Machine's Service Mode

1) Obtain the Test Chart.

If the Test Chart is not available, prepare one using A4 or LTR paper as follows:

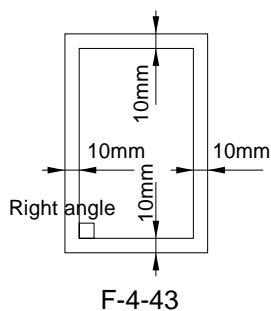

2) Place the Test Chart in the original pickup tray, and make a copy at a 100% reproduction ratio.

3) Put the Test Chart over the output of step 2), and check to see that the following is true

A \leq 1 mm

B \leq 1 mm

If not, go to step 4).

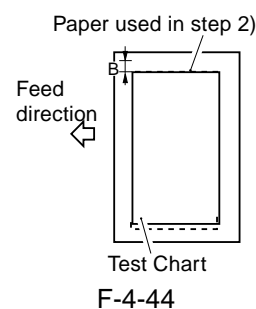
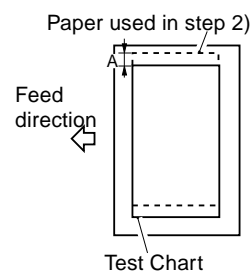

4) Start service mode as follows: press the User Mode key, press the 2 and 8 keys at the same time, and press the User Mode key once again.

5) Make the following selections: COPIER>ADJUST>ADJ-XY>ADY-Y-DF. Then, change the setting to make adjustments.

- A higher setting will increase the margin of A, decreasing the margin of B.

(in: 0.1 m)

(range: -30 to 30)

6) Make a copy of the Test Chart once again, and check to see that the image is as indicated.

b. Adjusting the Side Guide Plate Position of the ADF Original Pickup Tray

1) Open the feeder cover, and detach the inside cover.

2) Remove the 3 mounting screws [1], and detach the cover [2].

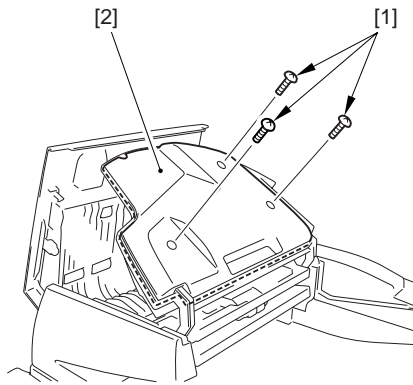

F-4-45

- 3) Loosen the mounting screw [1], and remove the screw [2] from the positioning hole, and fit it and temporarily tighten it in the adjusting angular hole [3].
 - if $A > 1$ mm, move the volume unit [6] to the front.
 - if $B > 1$ mm, move the volume unit [6] to the rear.

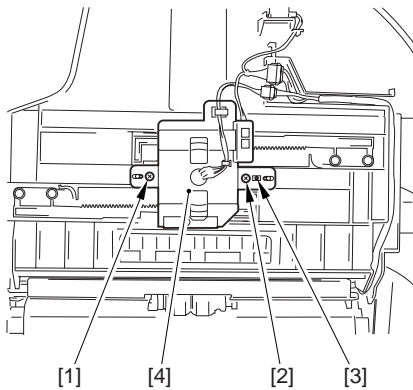

F-4-46

- 4) Move the original width volume unit [4] to the front or the rear to make adjustments.
- 5) Tighten the screw [1] that has been tentatively tightened and the screw [3] that has been fitted in the adjusting angular hole.
- 6) When done, mount back the cover.
- 7) Make a copy of the Test Chart once again, and see that the image is as indicated.

4.3.1.11 Leading Edge Registration

0003-2362

- 1) Obtain the Text Chart.

If the Text Chart is not available, make one using A4 or LTR paper as follows:

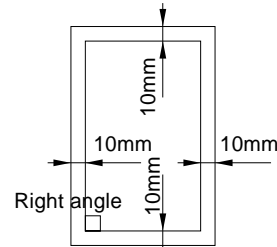

F-4-47

- 2) Place the Text Chart in the original tray, and make a copy of it at a 100% reproduction ratio.

- 3) Check to see that dimension A of the Test Chart and the image obtained in step 2) are as indicated:

$$A \leq 1 \text{ mm}$$

$$B \leq 1 \text{ mm}$$

If not, go to step 4).

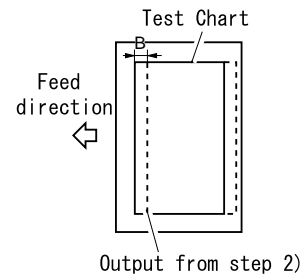
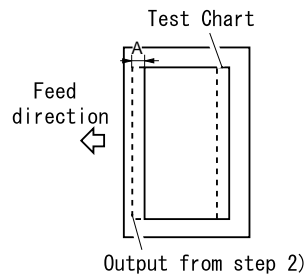

F-4-48

- 4) Start service mode as follows: press the User Mode key, press the 2 and 8 keys at the same time, and press the User Mode key once again.

- 5) Make the following selections:

FEEDER>ADJUST>DOCST. Then, change the setting to make adjustments.

- if A \geq 1 mm, increase the setting (so that the margin will be increased).

- if B \geq 1 mm, decrease the setting (so that the margin will be decrease).

(unit: 0.5 mm)

(range: -30- to 10; -5 to +5 mm)

6) Make a copy of the Test Chart once again, and see the image is as indicated.

4.3.1.12 White Level 0003-2377

1) Place A4 or LTRR paper on the copyboard glass, and close the machine.

⚠ Make sure that the paper is not too small. Otherwise, white level may not be adjusted.

2) Make the following selections on the Service Mode screen to bring up the Adjustment screen: COPIER>FUNCTION>CCD.

3) Touch [DF-WLVL1] to highlight.

4) Press the OK key.

In response, the machine runs an auto adjustment session, and will indicate 'OK!' if it ends normally.

5) Remove the paper from the copyboard glass, and place it in the original pickup tray of the machine.

6) Press [DF-WLVL2] on the touch panel to highlight.

7) Press the OK key.

In response, the machine will run an auto adjustment session (duplexing stream reading).

8) Press the Reset key twice to end service mode.

4.3.1.13 Adjusting the Hinge Pressure 0003-1932

1) Open the ADF, and measure the height of the point at which it stops closing when let go.

2) Check to see if the height is 10 to 20 cm in range.

<If Not As Indicated>

1. if 10 cm or less, turn it counterclockwise using a hex wrench to make adjustments.

2. if 20 cm or more, turn it clockwise using a hex wrench to make adjustments.

Memo

Service Tool

hex wrench (8 mm); CK - 0540

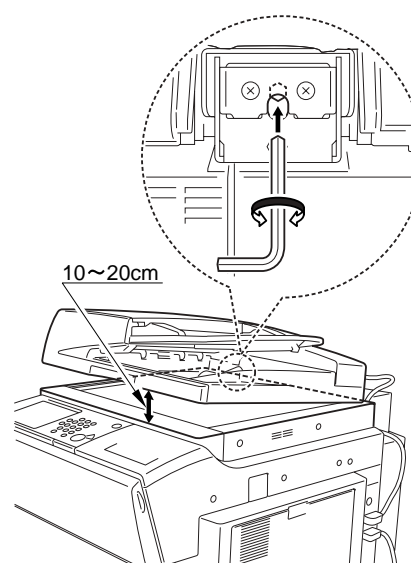

F-4-49

4.3.2 Adjustment at Time of Parts Replacement

4.3.2.1 Overview 0003-8360

Make the appropriate adjustments whenever you have replaced the following major parts:

· reader controller PCB (i.e., after EEPROM initialization)

- [1]sensor output
- [2]tray width
- [3]magnification
- [4]horizontal registration
- [5]leading edge registration
- [6]white level

- Post-separation sensor
[1]sensor output
- Read sensor
[1]sensor output
- Post-separation sensor
[1]sensor output
- Original detecting volume
[1]tray width

Memo:

For details of these adjustments, see the instructions given for basic adjustments.

If you have replaced the reader controller PCB (or initialized EEPROM), see the descriptions given under "After Replacing the Reader Controller PCB."

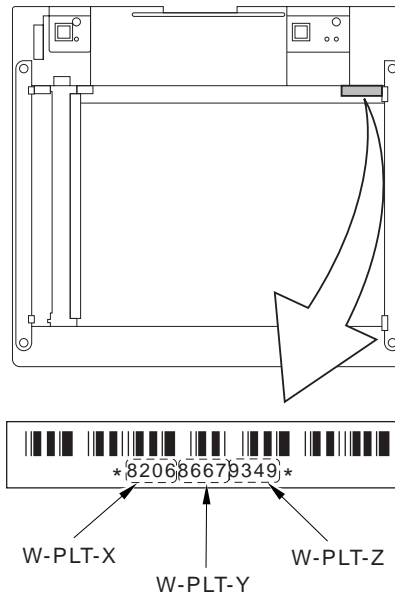

F-4-50

4.3.2.2 After Replacing the Reader Controller PCB 0004-9327

▲- Before actually replacing the reader controller PCB, be sure to generate a P-PRINT printout.

<if you are initializing the RAM of the reader controller without replacing the PCB>

- Using the SST, upload the R-CON backup data; then, download the data after initializing the RAM so that you need not make the following adjustments.

1. Reader Unit-Related Adjustments

1) Using the SST, download the latest system software (R-CON).

2) Make the following selections in service mode:

COPIER>FUNCTION>CLEAR>R-CON; then, press the OK key to initialize the RAM. Therefore, turn off and then on the main power.

3) Enter the following settings in service mode:

- a. standard white plate white level data
COPIER>ADJUST>CCD>W-PLT-X,Y,Z

b. service label settings (behind reader front cover)

b-1 image read start position adjustment (x direction; for fixed reading)

COPIER>ADJUST>ADJ-XY>ADJ-X

b-2 image read start position adjusting (Y direction; for fixed reading)

COPIER>ADJUST>ADJ-XY>ADJ-Y

b-3 shading position adjustment (for fixed reading)

COPIER>ADJUST>ADJ-XY>ADJ-S

b-4 feeder mode main scanning position adjustment

COPIER>ADJUST>ADJ-XY>ADJ-Y-DF

b-5 ADF stream reading CCD read position adjustment

COPIER>ADJUST>ADJ-XY>STRD-POS

b-6 CCD unit-dependent RG/GB sub scanning direction color displacement correction

COPIER>ADJUST>CCD>CCDU-RG/GB

b-7 factory default CCD unit-dependent RG/GB sub scanning direction color displacement correction value

COPIER>ADJUST>CCD>FCCDU-RG/GB

b-8 auto gradation correction target value

COPIER>ADJUST>PASCAL>OFST-P-

Y,M,C,K**2. ADF-Relate Adjustment**

⚠ The machine uses the RAM of the reader controller to store ADF-related service data. As such, you will have to make adjustments on the machine also if you have replaced the reader controller or initialized the RAM.

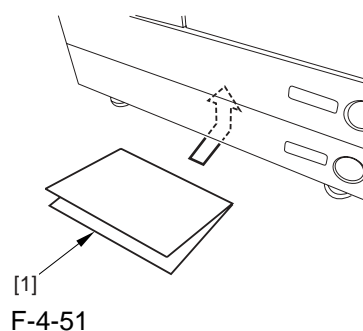

1) Enter the P-PRINT settings you have generated previously using service mode for the following items:

- a. leading edge registration adjustment

FEEDER>ADJSUT>DOCST

- b. original feed speed (100%) adjustment

FEEDER>ADUST>LA-SPEED

2) Make adjustments using the following service mode items:

- a. ADF sensor sensitivity adjustment

FEEDER>FUNCTION>SENS-INT

- b. tray width adjustment

FEEDER>FUNCTION>TRY-A4

FEEDER>FUNCTION>TRY-A5R

FEEDER>FUNCTION>TRY-LTR

FEEDER>FUNCTION>TRY-LTRR

- c. white level adjustment

COPIER>FUNCTION>CCD>DF-WLVL1

COPIER>FUNCTION>CCD>DF-WLVL2

When you have made all adjustment, put the P-PRINT printout [1] you have generated in the service book case, and dispose of the old P-PRINT printout.

4.4 Outline of Electrical Components

4.4.1 Sensors

0003-1671

T-4-5

Notation	Name		Description	
	Part No.	I/O >FEEDER	Connector No.	JAM/E code
PI1	Registration sensor		detects jam	
	WG8-5593	P001-1	J14	0003, 0004, 0043, 0044, 0094
PI2	Release HP sensor		detects pressed/released lock motor(M4)	
	WG8-5593	P005-1	J1	
PI3	AB/INCH identification sensor		identificate AB/inch system original	
	WG8-5593	P005-5	J3	
PI4	LGL sensor		identificate LGL/LTR size original	
	WG8-5593	P005-4	J3	
PI5	Original placement sensor		detects original on document tray	
	WG8-5593	P005-7	J2	0095
PI6	ADF cover open/closed sensor		detects cover open/close	
	WG8-5593	P004-0	J2	0092, 0093, 0095
PI7	Separation rear sensor		detects jam	
	FM2-1022	P005-3	J2	0001, 0002, 0042, 0045, 0046, 0094
PI8	Read sensor		measure original length, detects jam, controls original reading timing	
	FM2-1022	P001-0	J1	0005, 0006, 0094
PI9	Delivery reversal sensor		detects jam	
	FM2-1022	P001-2	J1	0007, 0008, 0047, 0048, 0094
LED1	Original placement indicator		indicate original placement on document tray	
	FM2-1023	P002-6	J2	

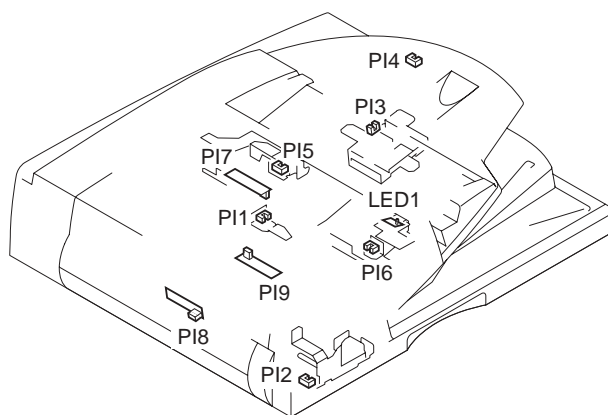

F-4-52

4.4.2 Motors, Clutches, Solenoids, PCBs, and Others

0003-1673

T-4-6

Notificat ion	Name		Description		
	Part No.	I/O >FEEDER	PART-CHK	E code	Connector No.
M1	Pickup motor		drives pickup system		
	FK2-0204	P003-6, 7	MTR- CHK>0		J11
M2	Feed motor		drives feed rollers		
	FK2-0205	P003-4, 5	MTR- CHK>1		J8
M3	Delivery reversal motor		drives delivery reverse roller, reversal roller		
	FK2-0217	P002-0, 1	MTR- CHK>2		J10
M4	Locking motor		locks read roller 1		
	FK2-0207	P002-2, 3	MTR- CHK>3	E413	J9
CL1	Pickup clutch		drives pickup roller		
	FK2-0209	P002-5	CL-CHK>0		J10
SL1	Stamp solenoid		drives stamp		
	FK2-0216	P002-4	SL-CHK>1		J1
SL2	Locking solenoid		presses delivery reverse roller (lower)		
	FK2-0210		SL-CHK>0		J9

Notificat ion	Name		Description		
	Part No.	I/O >FEEDER	PART-CHK	E code	Connector No.
FM1	Cooling fan		cools unit inside		
	FK2-0208	P002-7	FAN-CHK>0		J12
PCB1	ADF drive PCB		controls ADF		
	FM2-1021				
VR1	Original width volume		mesure original width		
	FK2-1024				J3

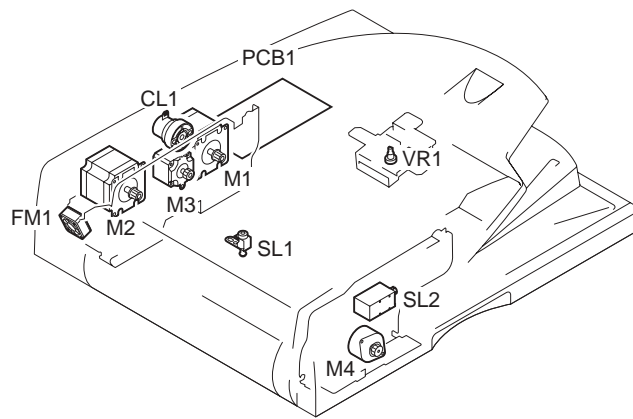

F-4-53

4.5 Variable Resistors (VR), Light-Emitting Diodes (LED), and Check Pins by PCB

4.5.1 Overview

0003-5520

Of the LEDs and check pins used in the machine, those needed for servicing the machine in the field are discussed.

⚠ Do not touch the check pins not indicated in the list. They are intended for use at the factory, and require special tools and high accuracy.

4.5.2 ADF Driver PCB

0003-5539

Some LEDs emit dim light even when they are off. This is a normal condition, and must be kept in mind.

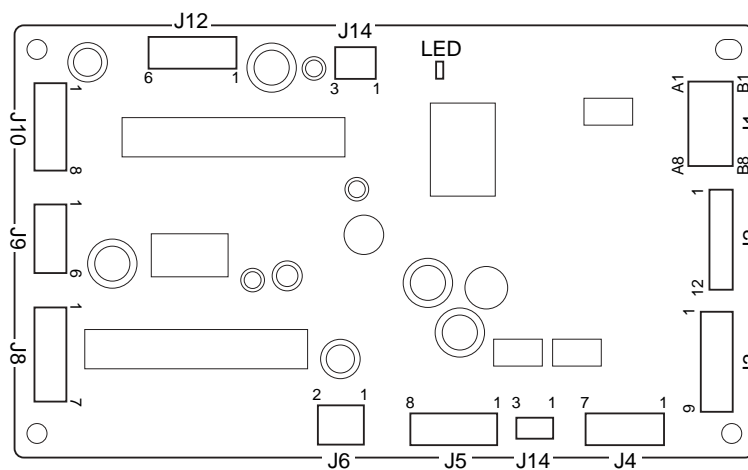

F-4-54

4.5.3 Original Placement led PCB

0003-5540

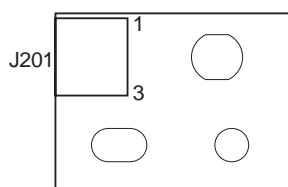

F-4-55

Chapter 5 Error Code

Contents

5.1 Overview	5-1
5.1.1 Overview	5-1
5.1.2 Error Code	5-2
5.2 User Error Code.....	5-3
5.2.1 Alarm Code	5-3

5.1 Overview

5.1.1 Overview

0004-5175

The CPU of the machine's ADF controller PCB is equipped with a function to monitor the state of the machine, flashing the Original Placement indicator when it finds a fault in the course of a check it runs as programmed. The machine communicates the presence of a fault to its host machine in the form of a code, which is any of the following 3 types; check the Original Placement indicator to find out the nature of a fault:

T-5-1

Nature of fault	Original Placement indicator
Alarm	flashes at intervals of 240 msec
Jam	flashes at intervals of 160 msec
Error	flashes at intervals of 80 msec

In addition, you may also use the host machine's service mode for a specific code for an alarm or jam; an error, on the other hand, will be indicated on the host machine's control panel in the form of an error code:

Display	I/O	Adjust	Function	Option	Test	Counter
< JAM >		< 1/7 >		< READY >		
No.	DATE	TIME1	TIME2	L	CODE	P CNTR SIZE
01	1031	1653	1653	1	0001	1 9399 A4
02	1030	1921	1923	0	0A11	0 0 -----
03	1030	1748	1748	1	0042	2 2515 A4
04	1030	1152	1152	1	0005	1 8668 A4
05	1029	1810	1813	0	010D	1 8096 A4
06	1029	1755	1756	0	0A08	0 0 -----
07	----	----	----	-	----	- ---- -----
08	----	----	----	-	----	- ---- -----
←		→				

F-5-1

5.1.2 Error Code

0004-5176

T-5-2

Code	Detail code	Item	Description
E400	A fault has been detected in the communication with th ADF driver PCB. Cause: there is an open circuit; there is a fault in the DC controller PCB.		
	0001	Check sum error	The check sum value of the data received from the ADF driver PCB fails to match 14 times continuously.
	0002	Status error	The status of the data received from the ADF drive PCB fails to match 14 times continuously.
	0003	Reception error	An SCI serial communication error interrupt has been detected 14 times continuously.
E413	The level of the locking HP sensor does not change within a specific period of time. Cause: there is a fault in the locking motor or the driver PCB; there is a fault in the locking HP sensor; there has been an increase in the load of the locking cam.		
	0001	Read roller 1 open	The level of the locking HP sensor does not change within a specific period of time after the locking motor has been driven.
	0002	Read roller 1 close	The level of the locking HP sensor does not change within a specific period of time after the locking motor has been driven.

5.2 User Error Code

5.2.1 Alarm Code

0004-5177

The machine flashes the original detection LED at intervals of 240 msec when it identifies a fault as being an alarm condition.

T-5-3

Code	Fault	Description
xx03	Separation has failed.	The 1st original does not reach the post-separation sensor. The 1st original does not reach the registration sensor.
xx11	The number of jam recovery sheets is greater than the number of originals.	In jam recovery mode, the tray runs out of originals before as many as 'the number of recovery sheets - 1' has been delivered.
xx13	An original has been pulled out.	The read sensor is off when the preceding original has been moved to a point of reading.
xx14	High-speed duplexing operation fails.	The original is longer than the specified limit.

Mar 22 2004

Canon